

# MA-SERIES THREE-PHASE INDUCTION MOTOR

## MA56 - 160 B3

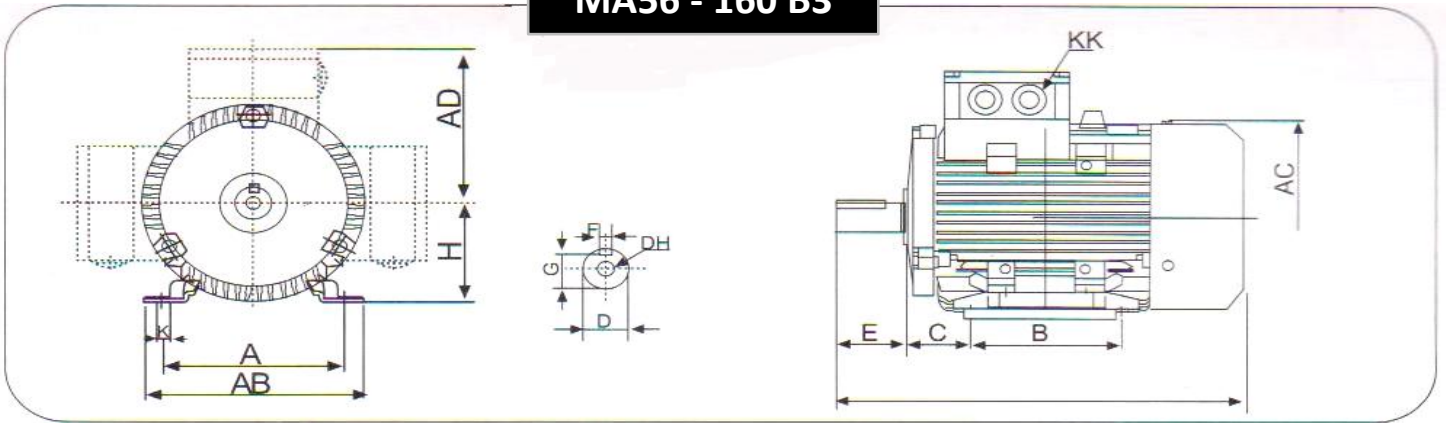

## MA56-160 B5/B35

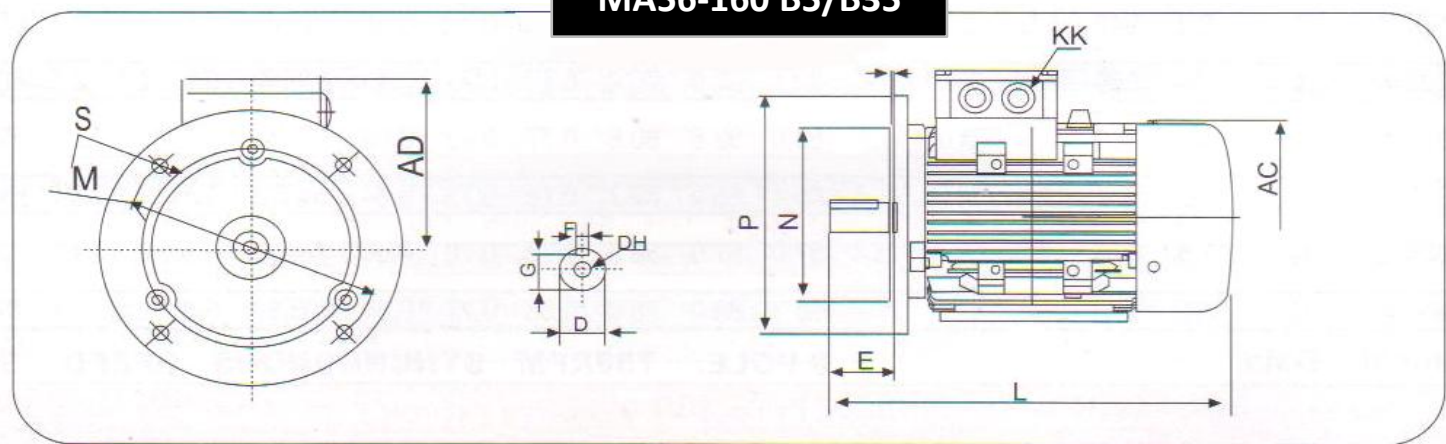

### MA56-160    B3                      B5/B35

FRAME	A	AB	AC	AD	B	C	D	DH	E	F	G	H	K	KK METRIC	PG	L	M	N	P	S	T
MA 56	90	115	110	100	71	36	9	M4X12	20	3	7.2	75	5.8	1-M20X1.5	1-PG 11	170	100	80	120	7	3
MA 63	100	135	130	115	80	40	11	M4X12	23	4	8.52	63	7	1-M20X1.5	1-PG 11		115	95	140	10	3
MA 71	112	150	145	120	90	45	14	M5X12	30	5	11	71	7	1-M20X1.5	1-PG 11	250	130	110	160	10	3.5
MA 80	125	165	175	145	100	50	19	M6X16	40	6	15.5	80	10	1-M25X1.5	1-PG 16		165	130	200	12	3.5
MA 90S	140	180	195	155	100	56	24	M8X19	50	8	20	90	10	1-M25X1.5	1-PG 16	315	165	130	200	12	3.5
MA 90L	140	180	195	155	125	56	24	M8X19	50	8	20	90	10	1-M25X1.5	1-PG 16		165	130	200	12	3.5
MA 100L	160	205	215	180	140	63	28	M10X22	60	8	24	100	12	1-M32X1.5	1-PG 21	385	215	180	250	15	4
MA 112M	190	230	240	190	140	70	28	M10X22	60	8	24	112	12	2-M32X1.5	2-PG 21		215	180	250	15	4
MA 132S	216	270	275	210	140	89	38	M12X28	80	10	33	132	12	2-M32X1.5	2-PG 21	470	265	230	300	15	4
MA 132M	216	270	275	210	178	89	38	M12X28	80	10	33	132	12	2-M32X1.5	2-PG 21		265	230	300	15	4
MA 160M	254	320	330	255	210	108	42	M16X36	110	12	37	160	15	2-M40X1.5	2-PG 29	615	300	250	350	19	5
MA 160L	254	320	330	255	254	108	42	M16X36	110	12	37	160	15	2-M40X1.5	2-PG 29		300	250	350	19	5