



Flameproof Motor

- Low Voltage
- Three Phase
- Ex d IIB T4
- Ex de IIC T4
- For hazardous areas

AEEBXZ AEVBXZ
AEHBXZ AEUBXZ



CE 1180  **II 2 G**

Ex d IIB T4

Ex de IIC T4

CE marking

Identification of the notified body responsible for the approval. 1180 is the identification number of Baseefa

The European Commission mark for Ex products

Surface Temperature

Gas group (IIB or IIC)

Ex d: Flameproof
Ex de: Flameproof motor with increased safety terminal box

Surrounding atmosphere: G for gas (D for dust)

Equipment category: 2 for Zone 1 or Zone 21 (1 for Zone 0 or 20, 3 for Zone 2 or 22)

Motor Group: II for non-mines(I for mines)

Name Plate

TECO FLAMEPROOF			
PREMIUM EFFICIENCY 3-PHASE INDUCTION MOTOR			
NOM. EFF.	MIN. EFF.	IP55	
TYPE	RATING	CONT.	
OUTPUT	kW Hz		
POLES	R. P. M.		
FRAME	VOLTS		
INS.	AMP' S		
BRG.	DATE		
WEIGHT	kg	AMB. TEMP.	°C
SER. NO.			
II 2 G Ex d IIB T4 / T3 (SINE POWER / PWM INVERTER) Baseefa0xATEXxxxxX BS EN 60079-1:2007 IECEX BAS0x,xxxxX IEC 60079-1:2007			
TECO Elec. & Mach. Co., Ltd.			
Post code:320			

Ex d IIB T4/T3
(Ambient Temperature: -20°C to +50°C)

Name Plate

TECO FLAMEPROOF			
PREMIUM EFFICIENCY 3-PHASE INDUCTION MOTOR			
NOM. EFF.	MIN. EFF.	IP55	
TYPE	RATING	CONT.	
OUTPUT	kW Hz		
POLES	R. P. M.		
FRAME	VOLTS		
INS.	AMP' S		
BRG.	DATE		
WEIGHT	kg	AMB. TEMP.	°C
SER. NO.			
II 2 G Ex de IIC T4 / T3 (SINE POWER / PWM INVERTER) Baseefa0xATEXxxxxX BS EN 60079-1:2007 IECEX BAS0x,xxxxX IEC 60079-1:2007			
TECO Elec. & Mach. Co., Ltd.			
Post code:320			

Ex de IIC T4/T3
(Ambient Temperature: -20°C to +50°C)

*** NOTE:**
T3 for inverter application
T4 for sinusoidal power

ATEX / IECEx Motors:

These series of motors are capable of withstanding pressure during an internal explosion so that such an explosion does not vent into the external atmosphere which could also be explosive.

They are also designed to prevent the occurrence of sparks, arcs, or hot spots in service, which avoids any further risk of explosion.

Impressive Design Features and the main characteristics:

- Three-phase, 50Hz
- Squirrel cage rotor
- Class "F" insulation
- Degree of protection IP55
- All Cast Iron frame
- Machined metal to metal surface between frame and terminal box
- Non-contact Seal
- Reinforced set screws
- Specified minimum values for creepage distances and clearances
- Tracking-proof isolating materials
- Six leads terminal block
- Suitable for outdoor use

Application

- Chemical and petrochemical industry
- Production of mineral oil and gas
- Flour / feed mills
- Grain elevators
- Fans
- Pumps
- Blowers

Optional Feature:

- Space heater



Hazardous area – Zone classification

SPECIFICATION TABLE,

Type – AEEBXZ 、 AEVBXZ 、 AEHBXZ 、 AEUBXZ

ITEM		STANDARD SPECIFICATION
R A T I N G	Kind of Motors	Squirrel Cage Induction Motors (SCIM).
	Design Standards	BS 4999, EN 60079-0, EN60079-1, EN 60079-7, IEC 60079-0, IEC 60079-1, IEC 60079-7, IEC 60034.
	Voltages	380V, 400V, 415V, 440V, Up to 690V.
	Frequency	50Hz, 60Hz.
	Output Range	0.18 ~ 110kW.
	R.P.M. (Syn.)	3000 ~ 750 R.P.M. (2 ~ 8 Poles).
	Time Duty	Continuous. S1, MCR (S.F. 1.0).
	Frame Size	80 ~ 280MC.
	Protection Enclosure	Totally Enclosed Fan Cooled , IP 55, IEC Ex / ATEX Explosion Proof.
	Cooling Method	Self External Fan, Surface Cooling (IC 411).
	Mounting	AEEBXZ 、 AEHBXZ : Horizontal Foot Mounting B3 (IM 1001). AEVBXZ 、 AEUBXZ : Flange Mounting V1(IM 3011)
A P P L I C A T I O N	Environment Conditions	Place : Zone 1 Hazardous, Ambient Temperature : -20°C ~ 50°C, Relative Humidity : Less Than 90%RH (Non - Condensation), Altitude : Less Than 1,000m.
	Hazardous Location	Suitable For Zone 1, Ex de Group II C, Ex d Group II B.
	Power Source Conditions	Voltage : $\pm 10\%$, Frequency : $\pm 5\%$, and $\pm 10\%$ of Combined Voltage and Frequency, But Frequency Variation Does Not Exceed $\pm 5\%$.
	Method of Starting	Full Voltage Direct On Line or $\lambda - \Delta$ Starting.
	Operating Conditions	For Belt-Drive Application. However for 2-Pole 22kW and Larger, Direct-Coupling Service Only.
	Direction of Rotation	Bi - Directional.
	Frame	High Grade Cast Iron Has Enough Strength Against Required Explosion Pressure.
C O N S T R U C T I O N	End Bracket	High Grade Cast Iron Has Enough Strength Against Required Explosion Pressure.
	External Fan	Conductive Polypropylene (Non-Sparking Material).
	Fan Cover.	Pressed Steel For F# 80 ~ 225MC & F# 280, Cast Iron For F# 250. (For Vertical Shaft Down Application Plus Steel Canopy)
	Shaft	Carbon Steel, Cylindrical Single Extension with Keyway and Key.
	Bearing	Bracket Mounting, Vacuum De Gassed High Quality Open Bearing for Frame NOS. 200L~280M, Grease Pre-Package Shielded Rolling Bearings for The Others.
	Lubricant	Mineral Oil, Li - Base Grease (MULTEMP SRL).
	Terminal Box	Cast Iron, Anti - Pressure Construction, Over Size, the Incoming Cable Hole in Metric Threaded.

SPECIFICATION TABLE,

Type – AEEBXZ 、 AEVBXZ 、 AEHBXZ 、 AEUBXZ

	ITEM	STANDARD SPECIFICATION	
C O N S T R U C T I O N	Shaft Opening Shield	Brass Flinger on Both Ends.	
	Lead Terminal	Max. 6 Leads, with Solderless Lug Terminals.	
	Iron Core	High Grade, Insulated, Cold - Rolled Electro - Magnetic Steel Plate.	
	Stator Winding	Pre-Formed, Random Wound, Made of Heavy, Polyester Enameled Copper Wire.	
	Stator Insulation	Class F Insulation System.	
	Varnish Treatment	Phenolic Alkyd Resin Varnish.	
	Rotor Winding	Squirrel Cage, Aluminum Conductor with End - Ring and Waffer Blades Integrally Cast.	
	Painting		AEEBXZ 、 AEVBXZ : Phenolic Rust Proof Base Plus Lacquer Surface Finished Painting in Blue - Gray Color (Munsell 7.5B 3.5/0.5).
			AEHBXZ 、 AEUBXZ : Phenolic Rust Proof Base Plus Lacquer Surface Finished Painting in Light-Gray Color (Munsell N5)
	Name Plate	Stainless Steel Plate.	
	Temperature Limiting Switch	150°C PTC Thermistor.	
Bolt Thread	ISO Metric System.		
Grounding Terminal	Insi de the Terminal Box and on the Frame .		
P E R F O R M A N C E	Test Procedure for Explosion Proof	According to EN 60079-0, EN 60079-1, EN 60079-7, IEC 60079-0, IEC 60079-1, IEC 60079-7.	
		BS 4999 and Full Voltage Measuring Starting Performance.	
	Test Procedure	BS 4999 and Full Voltage Measuring Starting Performance.	
	Winding Temperature Rise	Not to Exceed 80°C Rise By Resistance Method at S.F. 1.0.	
	External Surface Temperature	Comply with Operating Temperature Code T4 for Sinusoidal Power, T3 for PWM Inverter (Table 2 of IEC 60079-0),	
		Limited by Built-In PTC Thermistor.	
	Over Speed	120% Syn. R.P.M. for 2 Minutes.	
Over Torque	160% Rated Torque for 15 Sec.		

*Main standards complying with the "EHSR's" of Products Directive 94/9/EC (ATEX 95)

EN 60079-0 General requirements for gas

EN 60079-1 Flame proof enclosure 'd'

EN 60079-7 Equipment protection by increased safety 'e'

TECO Design Data, Continuous Output Under Converter/ Ex d ,Ex de, Temp. Code T3, TEFC (IC411)

50Hz rated Motor

Output	Torque value F rsie
Hz	F#80~280
5	75%
10	80%
15	85%
20	90%
25	92%
30	93%
35	95%
40	97%
45	98%
50	100%
60	83%
70	71%
80	63%
90	56%

Converter Duty Loadability/ Ex d, Ex de (50Hz Rated)

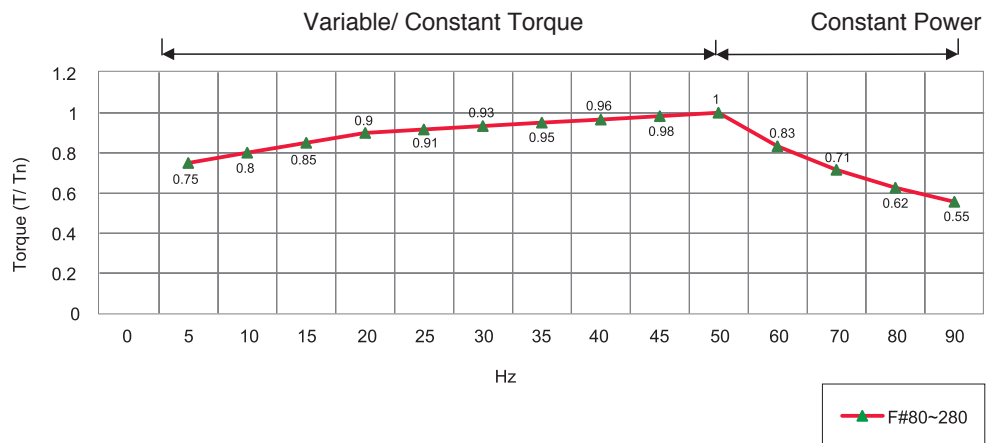

60Hz rated Motor

Output	Torque value F rsie
Hz	F#80~280
5	75%
10	88%
15	100%
20	100%
25	100%
30	100%
35	100%
40	100%
45	100%
50	100%
60	100%
70	86%
80	75%
90	67%

Converter Duty Loadability/ Ex d, Ex de (60Hz Rated)

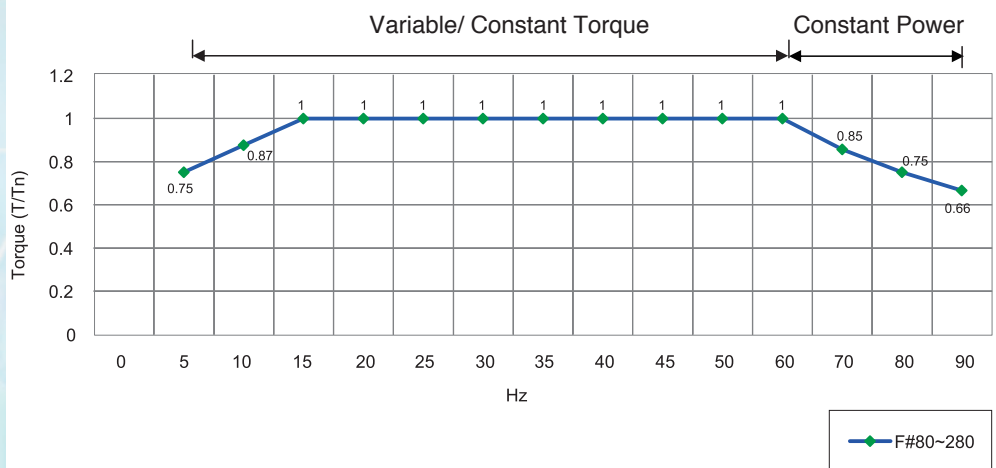

TECO Design Data, Continuous Output Under Converter/ Ex d ,Ex de, Temp. Code T3, TEFC (IC411)

The maximum safe operating speeds of the motor are indicated at the table below

(according to IEC60034-1 table 17)			(min-1)
Frame number	2P	4P	6P
≤ 100	5200	3600	2400
112	5200	3600	2400
132	4500	2700	2400
160	4500	2700	2400
180	4500	2700	2400
200	4500	2300	1800
225	3600	2300	1800
250	3600	2300	1800
280	3600	2300	1800
315	3600	2300	1800

Notes:

- 1) Installation: to follow the guidelines detailed in "IEC60034-17:2006 Cage induction motors when fed from converters - Application guide" within the certified Schedule of Variations.
- 2) Maximum safe operating speed to follow IEC60034-1, Table 17
- 3) With thermistor PTC 150°C (total 3, one per phase)
- 4) Converter operation parameter
 - F carrier(min.) 3kHz
 - IOL=1.5 IN, tOL=10s, tCOOL=10 min. (OL: Over Load)

PERFORMANCE DATA, Type – AEEBXZ \ AEVBXZ – IE1

TEFC, CLASS F, 50°C AMBIENT TEMP.
AS, BS & IEC DESIGN - N CONTINUOUS DUTY

50Hz / 415 V

OUTPUT		FULL LOAD RPM	FRAME SIZE	EFFICIENCY			POWER FACTOR			CURRENT		TORQUE				ROTOR GD ²
				FULL LOAD	3/4 LOAD	1/2 LOAD	FULL LOAD	3/4 LOAD	1/2 LOAD	FULL LOAD	LOCKED ROTOR	FULL LOAD	LOCKED ROTOR	PULL UP	BREAK-DOWN	
HP	kW			(%)	(%)	(%)	(%)	(%)	(%)	(A)	(A)	kg-m	%FLT	%FLT	%FLT	kg-m ²
1/4	0.18	705	80	52.0	48.0	39.0	47.0	41.0	34.0	1.06	4.00	0.257	360	350	370	0.010
		920	80	72.5	72.0	68.5	72.0	62.5	49.0	0.99	6.00	0.394	230	215	240	0.010
1/2	0.37	710	90S	70.5	68.0	62.5	60.0	51.0	39.5	1.23	6.00	0.511	195	190	265	0.017
		1425	80	72.0	69.5	64.0	70.0	59.5	46.5	1.54	8.00	0.382	240	210	290	0.007
3/4	0.55	910	80	68.0	68.0	63.0	72.0	62.0	49.0	1.59	6.00	0.598	230	210	230	0.012
		690	90L	70.0	70.0	66.0	70.0	61.0	49.0	1.59	6.00	0.789	170	145	205	0.023
1	0.75	2805	80	78.0	78.5	75.5	88.0	81.0	68.0	1.51	9.00	0.259	250	205	265	0.005
		1405	80	74.5	74.5	70.0	74.5	65.0	50.5	1.87	9.60	0.517	255	230	305	0.009
		935	90S	74.0	73.0	69.0	71.0	62.0	49.0	1.98	10.0	0.776	200	185	240	0.017
		700	100L	68.5	67.0	61.5	67.5	59.0	47.5	2.24	9.60	1.037	180	150	210	0.033
1.5	1.1	2780	80	79.5	80.5	78.5	87.5	82.5	72.0	2.24	15.0	0.392	275	250	280	0.006
		1425	90S	79.0	79.0	77.0	74.5	65.5	51.5	2.65	16.0	0.764	265	200	265	0.014
		935	90L	75.5	75.0	70.5	70.5	61.5	48.5	2.92	15.0	1.164	210	195	245	0.023
		690	100L	73.5	73.5	71.0	67.5	60.0	48.0	3.14	15.0	1.578	205	180	220	0.046
2	1.5	2820	90S	81.0	81.5	80.5	88.0	83.0	73.0	2.91	18.0	0.515	260	240	270	0.010
		1425	90L	81.0	81.0	79.0	78.0	70.0	56.0	3.29	21.0	1.019	265	205	270	0.017
		940	100L	79.0	80.0	77.5	73.5	65.5	52.5	3.57	18.0	1.544	210	190	230	0.037
		700	112M	75.0	74.5	70.5	66.0	58.0	46.0	4.19	19.0	2.074	185	150	240	0.059
3	2.2	2845	90L	84.0	85.0	84.5	88.0	83.5	74.0	4.21	28.0	0.765	240	230	290	0.014
		1425	100L	82.0	82.5	80.5	83.0	76.5	63.5	4.57	31.0	1.528	240	210	270	0.033
		950	112M	81.5	81.0	78.0	71.5	63.0	50.0	5.34	31.0	2.292	190	150	250	0.059
		710	132S	81.5	81.5	80.0	74.0	66.0	53.0	5.16	27.0	3.067	215	200	250	0.138
4	3.0	2845	100L	85.5	85.5	84.5	88.0	83.5	74.0	5.52	40.0	1.021	310	280	320	0.023
		1430	100L	83.0	82.0	80.0	81.0	73.5	61.0	6.17	49.0	2.030	310	270	340	0.046
		950	132S	83.0	82.5	81.0	79.0	73.5	63.0	6.33	39.0	3.056	210	200	270	0.125
		715	132M	82.5	81.5	78.0	67.0	58.0	46.0	7.51	45.0	4.061	250	200	290	0.180
5.5	4.0	2900	112M	85.5	86.0	85.0	90.0	87.0	78.5	7.42	63.0	1.377	230	220	360	0.042
		1440	112M	85.5	85.5	83.0	82.5	77.0	65.5	8.09	58.0	2.772	240	220	310	0.065
		955	132M	83.0	82.5	81.0	78.0	71.0	59.0	8.82	53.0	4.180	210	200	260	0.151
		720	160M	84.5	84.0	81.5	75.5	68.0	57.0	8.95	51.0	5.545	200	180	270	0.344
7.5	5.5	2915	132S	87.0	87.0	85.5	87.5	85.0	79.0	10.2	68.0	1.868	175	140	245	0.063
		1445	132S	86.0	85.0	83.5	82.5	76.0	64.0	11.0	72.0	3.767	240	200	280	0.103
		960	132M	85.0	84.0	81.0	76.0	68.5	56.0	12.0	77.0	5.671	250	230	310	0.217
		720	160M	85.5	85.5	83.0	78.0	70.5	58.0	11.7	70.0	7.561	200	180	270	0.484
10	7.5	2900	132S	88.5	89.0	88.0	89.0	87.0	82.0	13.2	87.0	2.503	215	190	260	0.076
		1465	132M	88.0	88.0	86.5	80.5	74.0	62.0	14.7	101	4.955	260	185	275	0.132
		970	160M	88.0	87.5	86.0	79.0	72.0	61.0	14.9	101	7.483	265	230	300	0.400
		720	160L	86.0	86.5	85.0	78.5	71.5	60.0	15.4	93.0	10.08	200	180	270	0.588
15	11	2940	160M	89.5	88.5	88.0	89.0	86.5	80.0	19.5	140	3.703	215	180	280	0.147
		1465	160M	90.0	90.0	89.0	86.0	82.0	73.0	20.1	140	7.432	235	190	280	0.297
		970	160L	88.5	88.5	86.5	83.0	77.0	66.5	21.2	149	11.22	275	230	300	0.588
		725	180LC	89.0	89.0	87.5	79.0	73.0	62.0	22.1	140	15.02	200	190	250	1.233

PERFORMANCE DATA, Type – AEEBXZ \ AEVBXZ – IE1

TEFC, CLASS F, 50°C AMBIENT TEMP.
AS, BS & IEC DESIGN - N CONTINUOUS DUTY

50Hz / 415 V

OUTPUT		FULL LOAD RPM	FRAME SIZE	EFFICIENCY			POWER FACTOR			CURRENT		TORQUE				ROTOR GD ²
HP	kW			FULL LOAD	3/4 LOAD	1/2 LOAD	FULL LOAD	3/4 LOAD	1/2 LOAD	FULL LOAD	LOCKED ROTOR	FULL LOAD	LOCKED ROTOR	PULL UP	BREAK-DOWN	
				(%)	(%)	(%)	(%)	(%)	(%)	(%)	(A)	(A)	kg-m	%FLT	%FLT	%FLT
20	15	2925	160M	90.5	90.5	90.0	91.0	91.0	87.0	25.2	169	4.963	215	180	270	0.183
		1460	160L	90.5	90.0	88.5	86.0	81.5	73.0	26.7	188	9.943	240	190	280	0.381
		965	180LC	90.0	91.0	91.0	85.0	83.0	76.0	27.1	159	15.04	200	155	230	1.233
		725	200LC	89.5	89.5	88.0	77.0	70.5	59.0	30.1	183	20.02	190	180	240	1.610
25	18.5	2925	160L	91.5	91.5	91.0	92.0	90.0	87.0	30.8	230	6.204	250	190	290	0.237
		1455	180MC	91.0	91.5	91.0	86.0	83.0	78.0	33.2	210	12.47	200	180	230	0.571
		975	200LC	91.0	91.5	90.5	83.5	80.0	70.0	34.1	225	18.61	210	190	250	1.610
		730	225SC	90.0	90.5	89.5	78.0	74.0	64.0	37.0	195	24.86	185	150	200	2.093
30	22	2940	180MA	92.0	92.5	92.0	91.0	90.0	85.5	37.2	260	7.407	220	170	270	0.283
		1475	180LC	91.5	91.5	91.0	83.0	78.0	68.5	41.0	300	14.76	230	175	270	0.770
		975	200LC	92.5	92.5	92.0	83.5	80.5	73.0	40.3	260	22.33	220	200	250	1.920
		730	225MC	91.0	91.0	90.0	78.5	72.0	63.0	43.6	230	29.830	200	175	220	2.442
40	30	2950	200LA	92.0	91.5	89.5	90.0	89.0	85.5	50.1	380	9.84	185	140	275	0.521
		1470	200LC	92.5	92.5	92.0	86.5	84.0	77.0	51.9	365	19.75	230	180	260	1.264
		980	225MC	92.0	92.0	89.5	81.5	77.0	67.5	55.4	335	29.627	220	190	240	2.326
		735	250SC	91.0	90.5	89.5	79.0	74.0	64.5	57.7	350	39.50	200	160	220	4.206
50	37	2955	200LA	93.0	92.5	91.0	88.0	86.0	80.5	63.4	415	12.28	180	145	235	0.633
		1475	225SC	92.5	92.0	91.0	85.0	82.0	73.5	66.0	460	24.605	205	175	275	1.649
		975	250SC	92.5	92.0	91.5	86.0	83.0	75.0	65.2	415	37.22	200	170	230	3.373
		735	250MC	91.5	91.5	90.0	80.0	76.5	66.0	70.9	415	49.38	210	175	220	5.669
60	45	2955	225MA	93.0	92.5	91.0	91.0	90.0	85.5	73.6	550	14.738	145	125	260	1.074
		1470	225MC	92.5	92.5	91.5	86.0	84.5	78.5	78.3	470	29.63	190	150	230	1.896
		975	250MC	93.0	92.5	91.5	84.5	81.5	74.0	79.2	510	44.67	220	180	240	3.829
		735	280SC	92.3	92.0	90.6	78.0	72.5	63.0	86.5	520	59.254	190	152	210	9.371
75	55	2965	250SA	94.0	93.0	92.0	89.5	86.5	82.5	92.5	720	18.36	160	150	320	1.410
		1480	250SC	93.6	93.0	92.0	87.0	85.0	78.5	95.6	720	36.78	260	230	260	3.621
		980	280SC	92.8	92.4	90.7	84.0	80.0	71.0	99.9	620	55.550	150	120	230	6.543
		735	280MC	92.8	92.5	91.2	78.0	73.0	63.0	108.0	620	74.07	190	152	210	11.870
100	75	2955	250MA	94.0	93.5	92.0	91.0	90.0	87.5	121.0	895	24.56	155	135	280	1.678
		1480	250MC	94.0	93.6	93.0	89.0	87.5	82.5	124.0	915	49.044	265	220	245	4.518
		980	280MC	93.8	93.5	91.0	85.5	81.5	72.0	129.0	850	74.07	150	120	240	8.724
125	90	2960	280SA	94.1	93.3	91.5	88.0	86.5	81.0	157.0	1045	30.65	150	120	250	2.520
		1480	280SC	94.1	93.9	92.5	87.5	84.0	80.0	158.0	1045	61.306	150	120	240	6.433
150	110	2960	280MA	94.5	93.9	92.0	88.5	87.0	82.0	186.0	1235	36.78	150	120	250	3.068
		1480	280MC	94.5	94.1	92.5	87.5	85.5	80.0	188.0	1255	73.57	150	120	230	8.100

- NOTE:**
1. The above are typical values based on test.
 2. Actual load & full voltage starting: According to BS 4999, AS 1359.
 3. Tolerance according to BS4999, AS1359.
 4. Efficiency, power factor, speed and torque are the same for other voltages.
 5. Data subject to change without notice.

PERFORMANCE DATA, Type – AEHBXZ \ AEUBXZ – IE2

TEFC, CLASS F, 50°C AMBIENT TEMP.
AS, BS & IEC DESIGN - N CONTINUOUS DUTY

50Hz / 415 V

OUTPUT		FULL LOAD RPM	FRAME SIZE	EFFICIENCY			POWER FACTOR			CURRENT		TORQUE				ROTOR GD ²
				FULL LOAD	3/4 LOAD	1/2 LOAD	FULL LOAD	3/4 LOAD	1/2 LOAD	FULL LOAD	LOCKED ROTOR	FULL LOAD	LOCKED ROTOR	PULL UP	BREAK-DOWN	
HP	kW			(%)	(%)	(%)	(%)	(%)	(%)	(%)	(A)	(A)	kg-m	%FLT	%FLT	%FLT
1	0.75	2860	80	82.0	82.0	79.0	85.0	78.5	65.5	1.49	12	0.254	340	340	380	0.006
		1420	80	82.5	82.5	80.5	71.0	61.0	47.0	1.77	12	0.511	330	320	330	0.011
		940	90S	78.0	78.0	75.0	67.5	58.0	46.0	1.97	12	0.772	200	200	250	0.019
1.5	1.1	2820	80	83.0	84.5	83.0	84.0	77.5	63.5	2.23	16	0.386	305	275	330	0.006
		1415	90S	84.0	85.0	84.0	80.0	72.5	60.0	2.32	16	0.769	250	215	270	0.017
		930	90L	79.9	80.0	78.5	69.5	60.5	47.0	2.80	16	1.171	210	210	255	0.025
2	1.5	2855	90S	85.0	85.5	83.0	85.5	80.5	68.0	2.86	23	0.508	330	300	330	0.011
		1430	90L	85.0	85.0	83.0	75.0	66.5	53.0	3.26	23	1.015	300	240	310	0.023
		935	100L	81.5	81.5	80.0	71.0	63.0	49.5	3.59	20	1.553	220	190	230	0.045
3	2.2	2855	90L	86.0	86.5	85.5	88.0	83.0	72.0	4.11	33	0.763	320	290	330	0.015
		1440	100L	86.5	86.5	85.0	82.5	76.0	63.5	4.36	33	1.512	290	250	300	0.041
		955	112M	85.0	85.5	85.0	70.0	62.5	50.0	5.23	30	2.280	175	170	235	0.071
4	3	2855	100L	86.7	87.0	86.0	88.5	85.0	75.5	5.41	48	1.017	360	310	340	0.023
		1440	100L	87.4	88.0	87.0	82.5	74.5	60.0	5.76	45	2.016	250	180	300	0.045
		965	132S	88.5	87.5	86.0	81.0	75.0	63.0	5.79	43	3.009	210	170	300	0.154
5.5	4	2895	112M	87.6	89.0	89.0	90.5	87.5	79.5	7.20	60	1.379	250	245	320	0.044
		1455	112M	88.3	88.0	87.0	79.5	72.0	59.0	8.13	65	2.744	230	200	345	0.071
		970	132M	89.5	89.0	87.0	79.0	72.5	60.0	8.07	60	4.116	210	180	310	0.205
7.5	5.5	2915	132S	91.5	91.5	90.5	88.0	85.0	78.5	9.67	75	1.868	220	190	280	0.076
		1460	132S	90.5	90.5	89.0	82.5	76.0	63.5	10.4	85	3.729	270	220	320	0.133
		960	132M	89.0	89.0	89.0	79.5	73.5	61.5	11.0	70	5.671	185	170	270	0.205
10	7.5	2895	132S	91.0	91.0	90.0	87.0	85.0	78.5	13.1	90	2.507	210	180	260	0.076
		1455	132M	91.0	91.0	90.0	85.0	80.0	68.5	13.4	110	4.989	270	220	320	0.173
		970	160M	91.0	91.0	90.0	81.0	75.0	64.0	14.1	95	7.483	240	200	260	0.484
15	11	2935	160M	92.5	92.5	92.0	91.5	89.0	84.5	18.4	140	3.710	230	200	280	0.183
		1460	160M	92.5	92.5	92.0	87.0	83.5	75.0	19.3	140	7.457	230	180	270	0.367
		975	160L	91.0	90.5	89.0	79.0	72.5	60.0	21.7	160	11.17	280	230	280	0.630

- NOTE:**
1. The above are typical values based on test.
 2. Actual load & full voltage starting: According to BS 4999, AS 1359.
 3. Tolerance according to BS4999, AS1359.
 4. Efficiency, power factor, speed and torque are the same for other voltages.
 5. Data subject to change without notice.



PERFORMANCE DATA, Type – AEHBXZ \ AEUBXZ – IE2

TEFC, CLASS F, 50°C AMBIENT TEMP.
AS, BS & IEC DESIGN - N CONTINUOUS DUTY

50Hz / 415 V

OUTPUT		FULL LOAD RPM	FRAME SIZE	EFFICIENCY			POWER FACTOR			CURRENT		TORQUE				ROTOR GD ²
				FULL LOAD	3/4 LOAD	1/2 LOAD	FULL LOAD	3/4 LOAD	1/2 LOAD	FULL LOAD	LOCKED ROTOR	FULL LOAD	LOCKED ROTOR	PULL UP	BREAK-DOWN	
HP	kW			(%)	(%)	(%)	(%)	(%)	(%)	(A)	(A)	kg-m	%FLT	%FLT	%FLT	kg-m ²
20	15	2935	160M	92.5	92.0	91.5	91.0	88.0	81.0	24.7	195	4.946	240	210	290	0.183
		1460	160L	93.0	93.0	92.5	88.0	84.5	76.5	25.4	185	9.943	230	180	270	0.462
		970	180LC	91.5	92.0	92.0	84.0	79.5	71.5	27.0	165	14.97	230	190	250	1.342
25	18.5	2925	160L	93.0	93.0	93.0	91.5	89.5	84.0	30.5	245	6.204	260	210	300	0.237
		1470	180MC	94.0	94.0	93.5	85.0	81.0	72.5	32.5	245	12.34	240	180	270	0.746
		975	200LC	93.0	93.5	93.0	81.0	77.5	68.5	34.4	220	18.61	230	200	250	1.835
30	22	2935	180MA	93.5	93.5	92.5	87.5	84.5	76.0	38.1	300	7.419	250	210	300	0.302
		1465	180LC	94.0	94.0	93.5	86.0	82.5	74.0	38.5	270	14.86	230	180	270	0.850
		975	200LC	93.0	93.5	93.5	83.0	80.5	72.5	40.3	260	22.33	215	180	230	2.078
40	30	2955	200LA	94.0	94.0	93.0	89.0	87.5	83.5	49.6	340	9.825	175	150	260	0.605
		1470	200LC	94.5	94.5	94.5	87.0	85.5	78.0	50.5	390	19.75	230	190	270	1.454
		980	225MC	94.0	94.0	93.5	85.5	82.0	75.0	51.7	305	29.63	210	190	230	3.023
50	37	2950	200LA	94.5	94.5	93.5	90.0	88.0	84.5	61.0	400	12.30	155	135	260	0.757
		1475	225SC	95.0	95.0	94.5	85.0	81.0	73.0	64.3	430	24.61	200	180	240	1.896
		985	250SC	94.0	94.5	94.0	87.0	83.5	76.0	63.5	405	36.85	210	200	250	4.194
60	45	2955	225MA	94.5	94.5	93.5	92.0	91.0	88.0	71.6	480	14.74	140	130	230	1.244
		1475	225MC	95.0	95.0	94.5	85.0	81.0	72.5	77.1	495	29.53	200	175	250	1.979
		985	250MC	94.5	95.0	94.5	87.5	85.0	77.5	75.3	530	44.21	230	200	250	5.106
75	55	2960	250SA	95.0	94.5	94.0	89.5	88.0	87.0	91.5	645	18.39	150	130	250	1.547
		1480	250SC	95.5	95.0	94.5	87.0	84.0	77.0	93.7	655	36.78	230	200	260	3.911
		977	280SC	94.5	94.0	91.8	84.1	80.2	74	97.9	616	55.72	146	121	221	7.383
100	75	2960	250MA	95.5	95.5	95.0	91.0	88.0	85.0	119	825	24.52	140	130	250	1.816
		1480	250MC	95.5	95.5	95.0	87.0	84.0	77.0	125	810	49.04	220	180	240	4.490
		978	280MC	95.0	94.2	92.1	85.7	81.5	74.4	127	852	74.22	141	119	220	9.536
125	90	2970	280SA	95.2	95.0	92.7	89.8	87.6	85.5	152	1024	30.55	133	112	222	2.739
		1480	280SC	95.4	95.1	93.1	87.7	84.2	80.4	155	1022	61.31	145	123	223	7.386
150	110	2970	280MA	95.3	95.1	92.9	90.0	87.8	85.8	182	1192	36.66	122	105	216	3.178
		1483	280MC	95.5	95.4	93.2	88.0	85.9	81.0	154	1190	61.18	128	108	214	8.339

- NOTE:**
1. The above are typical values based on test.
 2. Actual load & full voltage starting: According to BS 4999, AS 1359.
 3. Tolerance according to BS4999, AS1359.
 4. Efficiency, power factor, speed and torque are the same for other voltages.
 5. Data subject to change without notice.



DIMENSIONS

Totally Enclosed Fan Cooled, Horizontal Foot Mounting Type AEEBXZ \ AEHBXZ

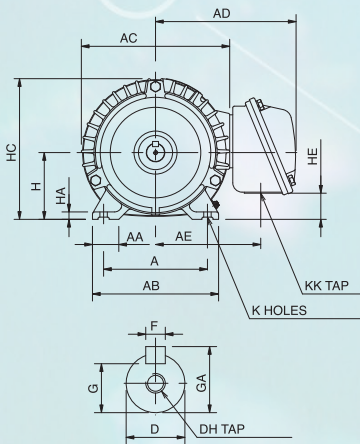

FIG. 1

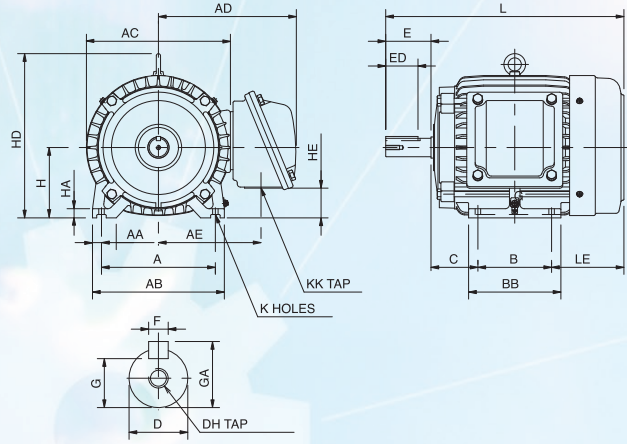

FIG. 2

Dimension in mm

Output (kW)				FRAME	FIG.	A	AA	AB	AC	AD	AE	B	BB	C	H	HA	HD	HE
2P	4P	6P	8P	SIZE	NO.													
0.75	0.55	0.37	0.18	80	1	125	35.5	155	180	211	146.0	100	130	50	80	9.0	—	26.5
1.1	0.75	0.55		90S		140	35.5	170	204	220	159.0	100	130	56	90	10.0	—	36.5
1.5	1.1	0.75	0.37	90L		140	35.5	170	204	220	159.0	125	150	56	90	10.0	—	36.5
2.2	1.5	1.1	0.55	100L	2	160	45.0	195	223	230	168.5	140	175	63	100	12.5	243	46.5
3	2.2	1.5	0.75	100L		190	45.0	224	242	237	178.0	140	175	70	112	14.0	265	58.5
4	4	2.2	1.5	112M														

FRAME	FIG.	SHAFT EXTENSION				BEARING		APPROX.							
SIZE	NO.	K	KK	L	LE	D	E	ED	F	G	GA	DH	DRIVE END	OPPOSITE DRIVE END	WEIGHT KGS
80	1	10	M20X1.5	282.0	92.0	19	40	25	6	15.5	21.5	M6×12	6204ZZC3	6204ZZC3	22
90S		10	M20X1.5	309.0	103.0	24	50	32	8	20.0	27.0	M8×16	6205ZZC3	6205ZZC3	32
90L		10	M20X1.5	337.5	106.5	24	50	32	8	20.0	27.0	M8×16	6205ZZC3	6205ZZC3	35
100L	2	12	M20X1.5	374.5	111.5	28	60	40	8	24.0	31.0	M10×20	6206ZZC3	6305ZZC3	45
112M		12	M20X1.5	391.0	121.0	28	60	40	8	24.0	31.0	M10×20	6306ZZC3	6306ZZC3	55

- NOTE:** 1. Tolerance of shaft end diameter D: $\phi 19 \sim \phi 28: j6$.
 2. Tolerance of shaft center height H+0, -0.5.
 3. IEC Dimension is optional.

DIMENSIONS

Totally Enclosed Fan Cooled, Horizontal Foot Mounting Type AEEBXZ \ AEHBXZ

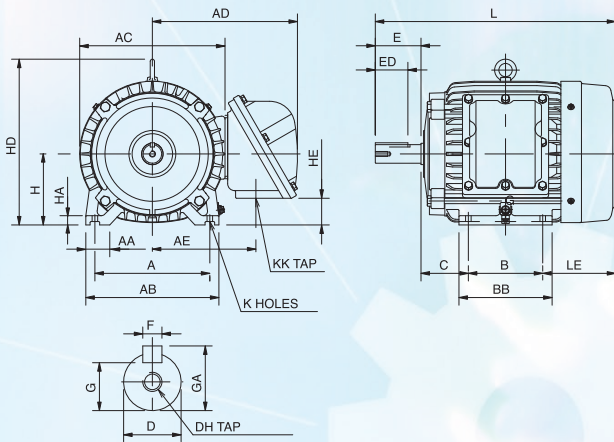

FIG. 3

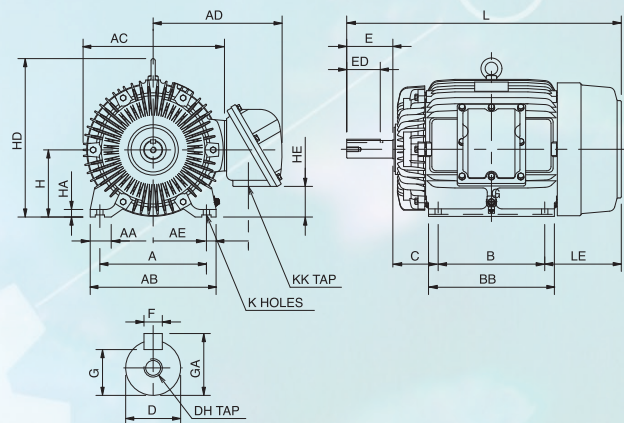

FIG. 4

Dimension in mm

Output (kW)				FRAME SIZE	FIG. NO.	A	AA	AB	AC	AD	AE	B	BB	C	H	HA	HD	HE
2P	4P	6P	8P			D	E	ED	F	G	GA	DH	DRIVE END	OPPOSITE DRIVE END	WEIGHT KGS			
5.5	5.5	3	2.2	132S	3	216	45	250	277	287	202.5	140	175	89	132	16	310	48
7.5	7.5	4	3	132M		216	45	250	277	287	202.5	178	212	89	132	16	310	48
11	11	7.5	4	160M	4	254	50	300	342	322	237	210	250	108	160	18	378	73
15	11	5.5	3	160L		254	50	300	342	322	237	254	300	108	160	18	378	73
18.5	15	11	7.5	180MA		279	75	355	391	347	262	241	297	121	180	20	431	93
22	—	—	—	180MC		279	75	355	391	347	262	241	297	121	180	20	431	93
—	18.5	—	—	180LC	279	75	355	391	347	262	279	335	121	180	20	431	93	
—	22	15	11	180LC	279	75	355	391	347	262	279	335	121	180	20	431	93	

- NOTE:** 1. Tolerance of shaft end diameter D: $\phi 38 \sim \phi 48: k6$.
 2. Tolerance of shaft center height H: $+0, -0.5$.
 3. IEC Dimension is optional.

DIMENSIONS

Totally Enclosed Fan Cooled, Horizontal Foot Mounting Type AEEBXZ \ AEHBXZ

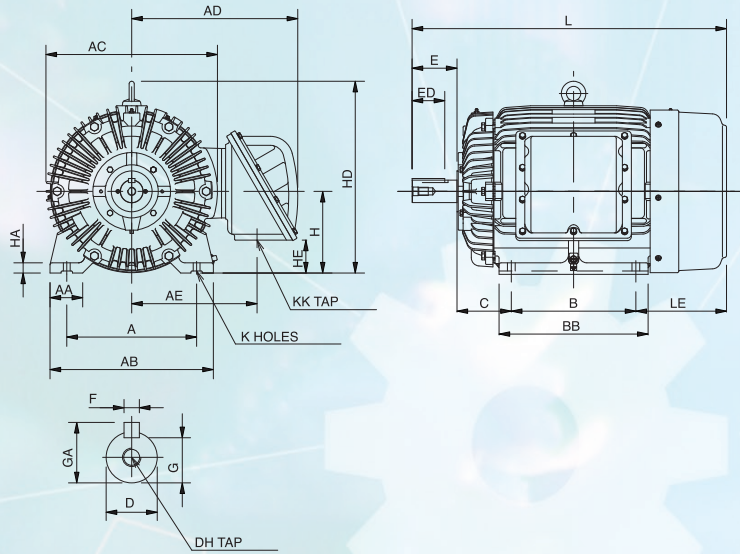

FIG. 5

Dimension in mm

Output (kW)				FRAME	FIG.	A	AA	AB	AC	AD	AE	B	BB	C	H	HA	HD	HE
2P	4P	6P	8P	SIZE	NO.													
30	—	—	—	200LA	5	318	80	400	420	411	307	305	365	133	200	25	470	81
—	30	18.5	15	200LC		318	80	400	420	411	307	305	365	133	200	25	470	81
—	37	—	18.5	225SC		356	90	450	458	431	327	286	375	149	225	30	525	116
45	—	—	—	225MA		356	90	450	458	431	327	311	375	149	225	30	525	116
—	45	30	22	225MC		356	90	450	458	431	327	311	375	149	225	30	525	116

FRAME	FIG.	SHAFT EXTENSION						BEARING		APPROX.					
SIZE	NO.	K	KK	L	LE	D	E	ED	F	G	GA	DH	DRIVE END	OPPOSITE DRIVE END	WEIGHT KGS
200LA	5	18.5	M50X1.5	770.0	222.0	55	110	80	16	49.0	59.0	M20×40	6312C3	6212C3	335
200LC		18.5	M50X1.5	770.0	222.0	55	110	80	16	49.0	59.0	M20×40	6312C3	6212C3	365
225SC		18.5	M50X1.5	841.0	241.0	60	140	110	18	53.0	64.0	M20×40	6313C3	6213C3	415
225MA		18.5	M50X1.5	811.0	241.0	55	110	80	16	49.0	59.0	M20×40	6312C3	6212C3	435
225MC		18.5	M50X1.5	841.0	241.0	60	140	110	18	53.0	64.0	M20×40	6313C3	6213C3	445

- NOTE:** 1. Tolerance of shaft end diameter D: $\phi 55 \sim \phi 85$: m6.
 2. Tolerance of shaft center height H: +0,-0.5.
 3. IEC Dimension is optional.

DIMENSIONS

Totally Enclosed Fan Cooled, Horizontal Foot Mounting Type AEEBXZ \ AEHBXZ

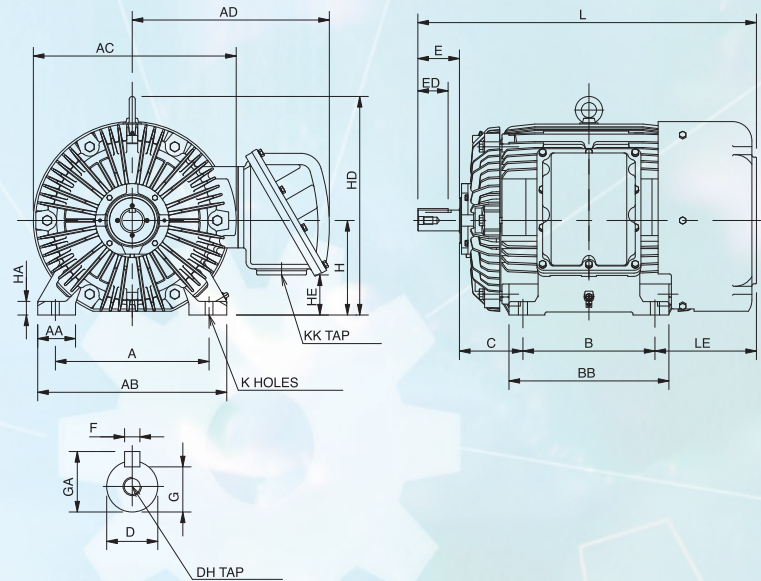

FIG. 6

Dimension in mm

Output (kW)				FRAME	FIG.	A	AA	AB	AC	AD	AE	B	BB	C	H	HA	HD	HE
2P	4P	6P	8P	SIZE	NO.													
55	-	-	-	250SA	6	406	100	500	530	525	395	311	385	168	250	36	598	106
-	55	37	30	250SC		406	100	500	530	525	395	311	385	168	250	36	598	106
75	-	-	-	250MA		406	100	500	530	525	395	349	425	168	250	36	598	106
-	75	45	37	250MC		406	100	500	530	525	395	349	425	168	250	36	598	106
90	-	-	-	280SA		457	110	560	592	555	425	368	445	190	280	40	655	131
-	90	55	45	280SC		457	110	560	592	555	425	368	445	190	280	40	655	131
110	-	-	-	280MA		457	110	560	592	555	425	419	495	190	280	40	655	131
-	110	75	55	280MC		457	110	560	592	555	425	419	495	190	280	40	655	131
FRAME	FIG.	K	KK	L	LE	SHAFT EXTENSION						BEARING		APPROX.				
SIZE	NO.					D	E	ED	F	G	GA	DH	DRIVE END	OPPOSITE DRIVE END	WEIGHT KGS			
250SA	6	24.0	M63X1.5	887.5	268.5	60	140	110	18	53.0	64.0	M20×40	6313C3	6313C3	567			
250SC		24.0	M63X1.5	887.5	268.5	70	140	110	20	62.5	74.5	M20×40	6317C3	6313C3	580			
250MA		24.0	M63X1.5	925.5	268.5	60	140	110	18	53.0	64.0	M20×40	6313C3	6313C3	630			
250MC		24.0	M63X1.5	925.5	268.5	70	140	110	20	62.5	74.5	M20×40	6317C3	6313C3	670			
280SA		24.0	M63X1.5	992.0	294.0	65	140	110	18	58.0	69.0	M20×40	6314C3	6313C3	712			
280SC		24.0	M63X1.5	1022.0	294.0	80	170	140	22	71.0	85.0	M20×40	NU318C3	6318C3	809			
280MA		24.0	M63X1.5	1042.0	293.0	65	140	110	18	58.0	69.0	M20×40	6314C3	6313C3	782			
280MC		24.0	M63X1.5	1072.0	293.0	80	170	140	22	71.0	85.0	M20×40	NU318C3	6318C3	906			

NOTE: 1. Tolerance of shaft end diameter D: $\phi 55 \sim \phi 80$: m6.
 2. Tolerance of shaft center height H: F#250: +0, -0.5; F#280: +0, -1.
 3. IEC Dimension is optional.

DIMENSIONS

Totally Enclosed Fan Cooled, Vertical Flange Mounting Type AEVBXZ \ AEUBXZ

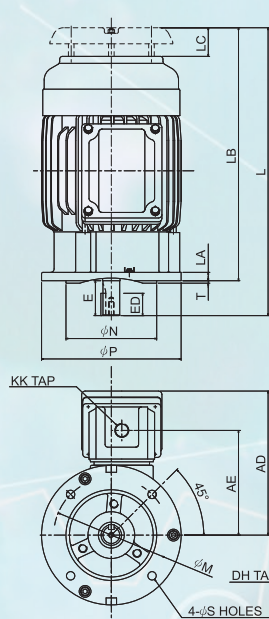

FIG. 1

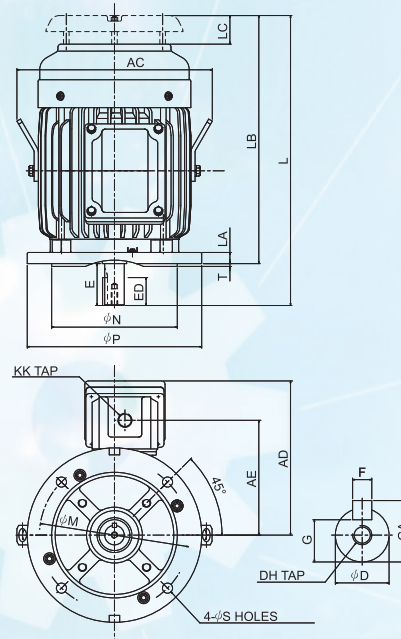

FIG. 2

Dimension in mm

Output (kW)				FRAME	FIG.	AC	AD	AE	L	LA	LB	M	N	P	S	T
2P	4P	6P	8P	SIZE	NO.											
0.75 1.1	0.55 0.75	0.37 0.55	0.18	80	1	-	211	152.0	335.5	12	295.5	165	130	200	12	3.5
1.5	1.1	0.75	0.37	90S		-	220	161.0	387.5	12	337.5	165	130	200	12	3.5
2.2	1.5	1.1	0.55	90L		-	220	161.0	412.5	12	362.5	165	130	200	12	3.5
3	2.2 3	1.5	0.75 1.1	100L	2	280	230	170.5	415.5	16	355.5	215	180	250	14.5	4.0
4	4	2.2	1.5	112M		300	237	178.5	479.0	16	419.0	215	180	250	14.5	4.0

FRAME SIZE	FIG. NO.	KK	SHAFT EXTENSION							BEARING		APPROX. WEIGHT KGS
			D	E	ED	F	G	GA	DH	DRIVE END	OPPOSITE DRIVE END	
80	1	M20X1.5	19	40	25	6	15.5	21.5	M6×12	6204ZZC3	6204ZZC3	24
90S		M20X1.5	24	50	32	8	20.0	27.0	M8×16	6205ZZC3	6205ZZC3	35
90L		M20X1.5	24	50	32	8	20.0	27.0	M8×16	6205ZZC3	6205ZZC3	39
100L	2	M20X1.5	28	60	40	8	24.0	31.0	M10×20	6206ZZC3	6305ZZC3	49
112M		M20X1.5	28	60	40	8	24.0	31.0	M10×20	6306ZZC3	6306ZZC3	60

NOTE: 1. Tolerance of shaft end diameter D: $\phi 19 \sim \phi 28$: j6.
 2. Tolerance of N: h7.
 3. IEC Dimension is optional.

DIMENSIONS

Totally Enclosed Fan Cooled, Vertical Flange Mounting Type AEVBXZ \ AEUBXZ

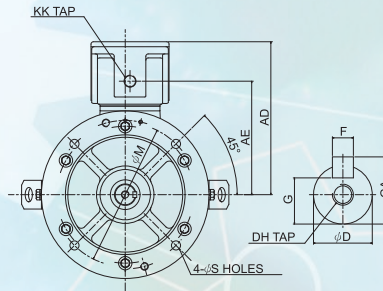
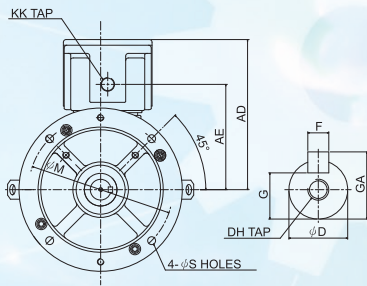
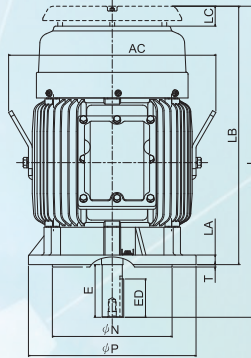
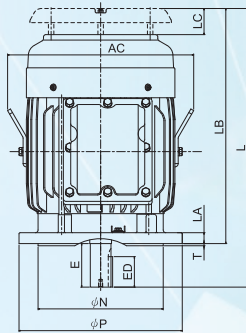

FIG. 3

FIG. 4

Dimension in mm

Output (kW)				FRAME SIZE	FIG. NO.	AC	AD	AE	L	LA	LB	M	N	P	S	T
2P	4P	6P	8P													
5.5	5.5	3	2.2	132S	3	342	287	198.50	512	20	432	265	230	300	14.5	4
—	7.5	4	3	132M		342	287	198.50	550	20	470	265	230	300	14.5	4
11	11	7.5	4	160M	4	432	322	237.00	650	20	540	300	250	350	18.5	5
15	11	7.5	5.5	160L		432	322	237.00	694	20	584	300	250	350	18.5	5
18.5	15	11	7.5	180MA		482	347	262.00	722	20	612	300	250	350	18.5	5
22	—	—	—	180MC		482	347	262.00	722	20	612	300	250	350	18.5	5
—	18.5	—	—	180LC		482	347	262.00	760	20	650	300	250	350	18.5	5
—	22	15	11	180LC		482	347	262.00	760	20	650	300	250	350	18.5	5

FRAME SIZE	FIG. NO.	KK	SHAFT EXTENSION							BEARING		APPROX. WEIGHT KGS
			D	E	ED	F	G	GA	DH	DRIVE END	OPPOSITE DRIVE END	
132S	3	M25X1.5	38	80	64	10	33.0	41.0	M12X24	6308ZZC3	6306ZZC3	99
132M		M25X1.5	38	80	64	10	33.0	41.0	M12×24	6308ZZC3	6306ZZC3	112
160M	4	M25X1.5	42	110	80	12	37.0	45.0	M16×32	6309ZZC3	6307ZZC3	170
160L		M25X1.5	42	110	80	12	37.0	45.0	M16×32	6309ZZC3	6307ZZC3	195
180MA		M32X1.5	48	110	80	14	42.5	51.5	M16×32	6311ZZC3	6310ZZC3	200
180MC		M32X1.5	48	110	80	14	42.5	51.5	M16×32	6311ZZC3	6310ZZC3	253
180LC		M32X1.5	48	110	80	14	42.5	51.5	M16×32	6311ZZC3	6310ZZC3	281

NOTE: 1.Tolerance of shaft end diameter D: $\phi 38 \sim \phi 48$: k6.
 2.Tolerance of N: h7.
 3. IEC Dimension is optional.

DIMENSIONS

Totally Enclosed Fan Cooled, Vertical Flange Mounting Type AEVBXZ \ AEUBXZ

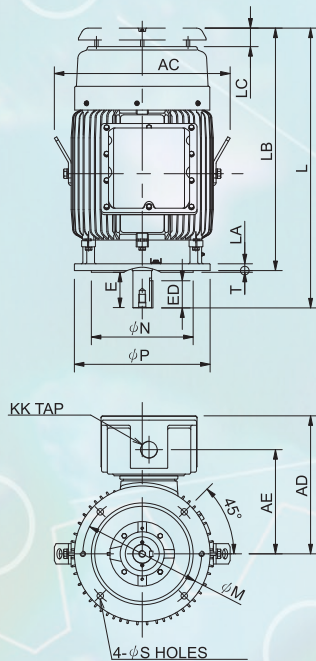

FIG. 5

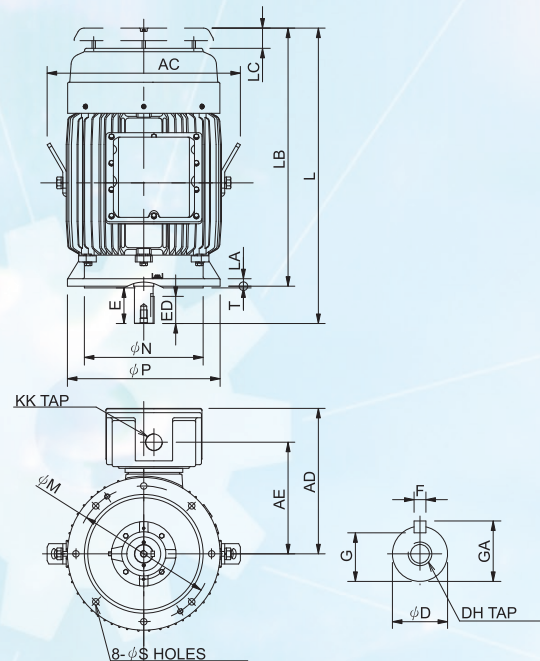

FIG. 6

Dimension in

Output (kW)				FRAME SIZE	FIG. NO.	AC	AD	AE	L	LA	LB	M	N	P	S	T
2P	4P	6P	8P													
30	—	—	—	200LA	5	518	411	307	825	20	715.0	350	300	400	18.5	5
37	—	—	—	200LC		518	411	307	825	20	715.0	350	300	400	18.5	5
—	30	18.5	15	225SC	6	570	431	327	876	22	736.0	400	350	450	18.5	5
—	37	—	18.5	225MA		570	431	327	871	22	761.0	400	350	450	18.5	5
45	—	—	—	225MC		570	431	327	901	22	761.0	400	350	450	18.5	5
—	45	30	22													
FRAME SIZE	FIG. NO.	KK	SHAFT EXTENSION							BEARING		APPROX. WEIGHT KGS				
			D	E	ED	F	G	GA	DH	DRIVE END	OPPOSITE DRIVE END					
200LA	5	M50X1.5	55	110	80	16	49	59	M20×40	6312C3	6212C3	377				
200LC		M50X1.5	55	110	80	16	49	59	M20×40	6312C3	6212C3	383				
225SC	6	M50X1.5	60	140	110	18	53	64	M20×40	6313C3	6213C3	436				
225MA		M50X1.5	55	110	80	16	49	59	M20×40	6312C3	6212C3	457				
225MC		M50X1.5	60	140	110	18	53	64	M20×40	6313C3	6213C3	467				

- NOTE:** 1. Tolerance of shaft end diameter D: $\phi 55 \sim \phi 60$: m6.
 2. Tolerance of N: h7.
 3. IEC Dimension is optional.

DIMENSIONS

Totally Enclosed Fan Cooled, Vertical Flange Mounting Type AEVBXZ \ AEUBXZ

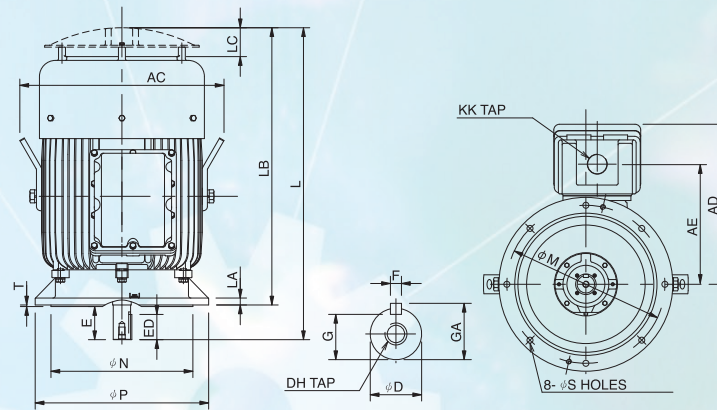

FIG. 7

Dimension in mm

Output (kW)				FRAME SIZE	FIG. NO.	AC	AD	AE	L	LA	LB	M	N	P	S	T
2P	4P	6P	8P													
55	—	—	—	250SA	7	626	525	395	979.0	22	839.0	500	450	550	18.5	5
—	55	37	30	250SC		626	525	395	979.0	22	839.0	500	450	550	18.5	5
75	—	—	—	250MA		626	525	395	1017.0	22	877.0	500	450	550	18.5	5
—	75	45	37	250MC		626	525	395	1017.0	22	877.0	500	450	550	18.5	5
90	—	—	—	280SA		655	555	425	1083.5	22	943.5	500	450	550	18.5	5
—	90	55	45	280SC		655	555	425	1113.5	22	943.5	500	450	550	18.5	5
110	—	—	—	280MA		655	555	425	1133.5	22	993.5	500	450	550	18.5	5
—	110	75	55	280MC		655	555	425	1163.5	22	993.5	500	450	550	18.5	5
FRAME SIZE	FIG. NO.	KK	SHAFT EXTENSION							BEARING		APPROX. WEIGHT KGS				
			D	E	ED	F	G	GA	DH	DRIVE END	OPPOSITE DRIVE END					
250SA	7	M63X1.5	60	140	110	18	53.0	64.0	M20×40	6313C3	6313C3	595				
250SC		M63X1.5	70	140	110	20	62.5	74.5	M20×40	6317C3	6313C3	609				
250MA		M63X1.5	60	140	110	18	53.0	64.0	M20×40	6313C3	6313C3	662				
250MC		M63X1.5	70	140	110	20	62.5	74.5	M20×40	6317C3	6313C3	704				
280SA		M63X1.5	65	140	110	18	58.0	69.0	M20×40	6314C3	6314C3	748				
280SC		M63X1.5	80	170	140	22	71.0	85.0	M20×40	NU318C3	6318C3	849				
280MA		M63X1.5	65	140	110	18	58.0	69.0	M20×40	6314C3	6314C3	821				
280MC		M63X1.5	80	170	140	22	71.0	85.0	M20×40	NU318C3	6318C3	951				

NOTE: 1. Tolerance of shaft end diameter D: $\phi 60 \sim \phi 80$: m6.
 2. Tolerance of N: h7.
 3. IEC Dimension is optional.

Motor Construction

Totally enclosed fan cooled, Horizontal Foot Mounting

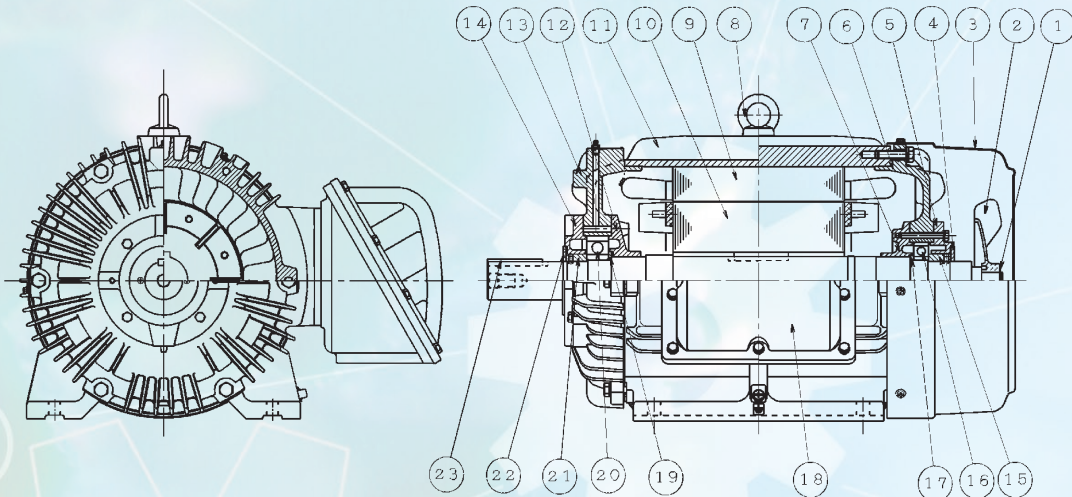

ITEM	NAME	ITEM	NAME
1	OUTSIDE RETAINING RING	13	BRACKET
2	EXTERNAL FAN	14	BEARING COVER-OUTER
3	FAN COVER	15	SHAFT SLEEVE
4	DUST FLINGER	16	BEARING
5	BEARING COVER-OUTER	17	STOP RING-BEARING
6	BRACKET	18	TERMINAL BOX ASSY
7	BEARING COVER-INNER	19	STOP RING-BEARING
8	EYE BOLT	20	BEARING
9	STATOR	21	SHAFT SLEEVE
10	ROTOR	22	DUST FLINGER
11	FRAME	23	KEY
12	BEARING COVER-INNER		

Motor Construction

Totally enclosed fan cooled, Vertical Flange Mounting

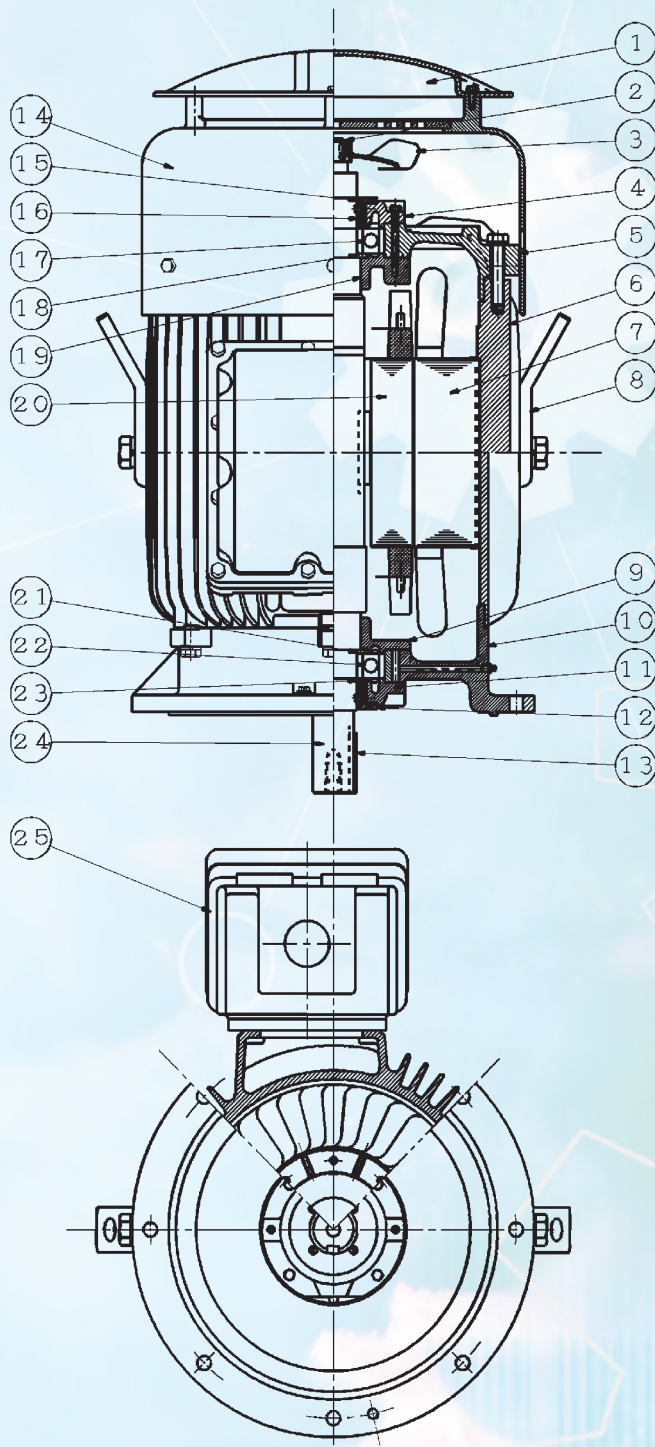

ITEM	NAME
1	WEATHER COVER
2	OUTSIDE RETAINING RING
3	EXTERNAL FAN
4	BEARING COVER-OUTER
5	END BRACKET
6	FRAME
7	STATOR
8	EYE BOLT
9	BEARING COVER - INNER
10	FLANGE BRACKET
11	BEARING COVER-OUTER
12	DUST FLINGER
13	KEY
14	FAN COVER
15	DUST FLINGER
16	SHAFT SLEEVE
17	BEARING
18	STOP RING - BERAING
19	BEARING COVER - INNER
20	ROTOR
21	STOP RING - BERAING
22	BEARING
23	SHAFT SLEEVE
24	SHAFT
25	TERMIANL BOX

HEAD OFFICE

Teco Electric & Machinery Co., Ltd
10F No.3-1, Yuan Cyu St.
Nan-Kang Taipei 115
Taiwan ROC
Tel: +886 2 6615 9111
www.teco.com.tw

UNITED STATES

Teco-Westinghouse Motor Company
PO Box 227 (78680-0277)
5100 N.IH35
Round Rock Texas 78681 USA
Tel: +1 512 255 4141
+1 800 873 8326
www.tecowestinghouse.com

CANADA

Teco-Westinghouse
Motors Inc. (Canada)
18060-109th Ave
Edmonton, Alberta T5S 2K2 Canada
Tel: +1 780 444 8933
Fax: (780) 486-4575
24 HR Emergency Pager:
(780) 419 7734
Toll Free: 800-661-4023
Fax Toll Free: 888-USE-TWMI
www.twmi.com

UNITED KINGDOM

Teco Electric Europe Ltd.
7 Dakota Avenue, Salford.
M50 2PU
Tel: +44 161 877 8025
Fax: +44 161 877 8030
www.teco.co.uk

MEXICO

Teco Westinghouse Motor Company
S.A. de C.V.
Circuito Mexiamora Poniente No. 321
Col. Puerto Interior,
Parque Santa Fe CP 36275
Silao, Guanajuato., México
Tel: +52 (472) 748 9016 al 20

NETHERLANDS

Teco Electric & Machinery B.V.
Teco's European Head Office
Rivium 3e Straat 27
2909 LH Capelle a/d IJssel
The Netherlands
Tel: +31 10 266 6633
Fax: +31 10 202 6415

GERMANY

Teco Electric & Machinery B.V.
Niederlassung Deutschland,
Marktstrasse 10
69 37441 Bad Sachsa
Germany
Tel: +49 5523 95340
Fax: +49 5523 953424
www.teco-westinghouse.de

SPAIN

Teco Electric & Machinery B.V.
Spain Office
C/Apostol Santiago, 38, 1-1
28017 Madrid, Spain
Tel/Fax: 34-91-326-30-91
E-mail: info@tecowestinghouse.es

TURKEY

OPTIMER Elektrik Makina Ltd.
Inonu cad. Sumko Sitesi M4-A blok
No: 2-kozyatagi-Istanbul 34742
Tel: +90-216-464 54 13Pbx.
Fax: +90-216-464 54 47

MIDDLE EAST

Teco Middle East Electric & Machinery
Co., Ltd.
Kingdom of Saudi Arabia Dammam City
P.O. Box 708 - Dammam 31421
Tel: +966 3 812 4823
Fax: +966 3 834 1678
www.teco-me.com

SAUDI ARABIA

Al Quraishi Electrical Services of S.A.
Al Quraishi Center, King Khalid Street,
P.O.Box 7386, Dammam-31462
Tel: +966 3 857-2537
Fax: +966 3 857-2541
www.aqesa.com

IRAN, AZERBAIJAN & ARMENIA

ATLAS DIBA Engineering & Trade Co.
No.3, Fakouri St., South Kadj Ave.
Golha Sq., Fatemi, Tehran, Iran
Tel: +98 21 88 33 03 81-3
Fax: +98 21 88 33 03 84
www.atlasdibaco.com

EGYPT

Amsol & Co.
38 Mossadak Street Dokki, Giza, Egypt
Tel: +202 333 79 774
Fax: +202 376 20 307

SOUTH AFRICA

ArmCoil Afrika (Pty) Ltd.
Unit 3 Prestige Park 127 Main Reef Road
Technikon Roodepoort
PO Box 500 Maraisburg 1700
Gauteng South Africa
Tel: +2711 763 2351
Fax: 0866 318 588
www.armcoil.co.za

AUSTRALIA

Teco Australia Pty Ltd.
335-337 Woodpark Road
Smithfield NSW 2164 Australia
Tel: +61 2 9765 8118
www.teco.com.au

NEW ZEALAND

Teco New Zealand Pty Ltd.
Unit 3, 477 Great South Road
Penrose Auckland New Zealand
Tel: +64 9 526 8480

JAPAN

Sankyo Co., Ltd.
26th fl. World Trading Center Bldg.
2-4-1 Hamamatsucho Minato-ku
Tokyo Japan 105-6126
Tel: +81 3 3435 9729
Fax: +81 3 3578 8381

SINGAPORE

Teco Electric & Machinery (PTE) Ltd.
18 chin Bee Drive
Singapore 619865
Tel: +65 6 265 4622
www.teco.com.sg

INDONESIA

P.T. Teco Multiguna Elektro
JL Bandengan Utara No. 83/1-2-3
Jakarta Utara-14440 Indonesia
Tel: +62 21 662 2201

CHINA

Shanghai Office
Rm 321 Building No.6
Lane 1279 Zhongshan W. Rd.
Shanghai, PRC
Tel: +86 21 5116 8255
Fax: +86 21 6278 8761

Wuxi Teco Electric & Machinery Co., Ltd
No. 9 South of Changjiang Road,
New Zone, Wuxi,
Jiangsu Province, PRC
Tel: +86 510 8534 2005
Fax: +86 510 8534 2001
www.wuxiteco.com

Jiangxi Teco Electric & Machinery Co., Ltd
189 Dongyuan Rd. Hi-Tech Zone, Nanchang
Jiangxi Province, PRC
Tel: +86 791 819 5999
Fax: +86 791 816 7730

Suzhou Teco Electric & Machinery Co., Ltd
No. 1 Changjiang W.Rd. Liuhe
Taicang City, Suzhou,
Jiangsu Province, PRC
Tel: +86 512 5361 9901
Fax: +86 512 5396 1058

Fujian Teco Precision Co., Ltd.
Xiayang, Jiazhao, Zhanggang Village, Saiqi
Development
Zone, Fuan, Fujian, China
Tel: +86 593 633 0300
Fax: +86 593 633 0303

HONG KONG

Tecoson Industrial Development
(HK) Co., Ltd.
Rm 3712 Hong Kong Plaza
186-191 Connaught Rd. West
Hong Kong
Tel: +852 2858 3220

MALAYSIA

Plo 52, Jalan Firma 2/1,
Kawasan Perindustrian Tebrau 1,
81100 Johor Bahru, Johor, Malaysia
Tel: (60) 7-3518862 / (60) 7-3548008
Fax: (60) 7-3546107

THAILAND

Teco Electric & Machinery
(Thai) Co., Ltd.
128/1 Soi Watsrivarenoi
Moo 7 Bangna-Trad Road Km 18
Bangchalong Bangplee
Samuthprakarn 10540 Thailand
Tel: +662 3371311- 20

VIETNAM

Teco(Vietnam) Electric & Machinery Co., Ltd
KCN LONG Thanh, Huyen Long Thanh,
Tinh Dong Nai. Vietnam
Tel: +84 61 3514151
Fax: +84 61 3514110

PHILIPPINES

Trade One
No. 56 Aragon Street San Francisco
Del Monte 1100 Quezon City Metro Manila,
Philippines
Tel: (632) 371-3032
Fax: (632) 371-1175
www.tradeoneinc.com