

WEH

Minerals

**WARMAN® Centrifugal
Slurry Pumps**

AH® Pump

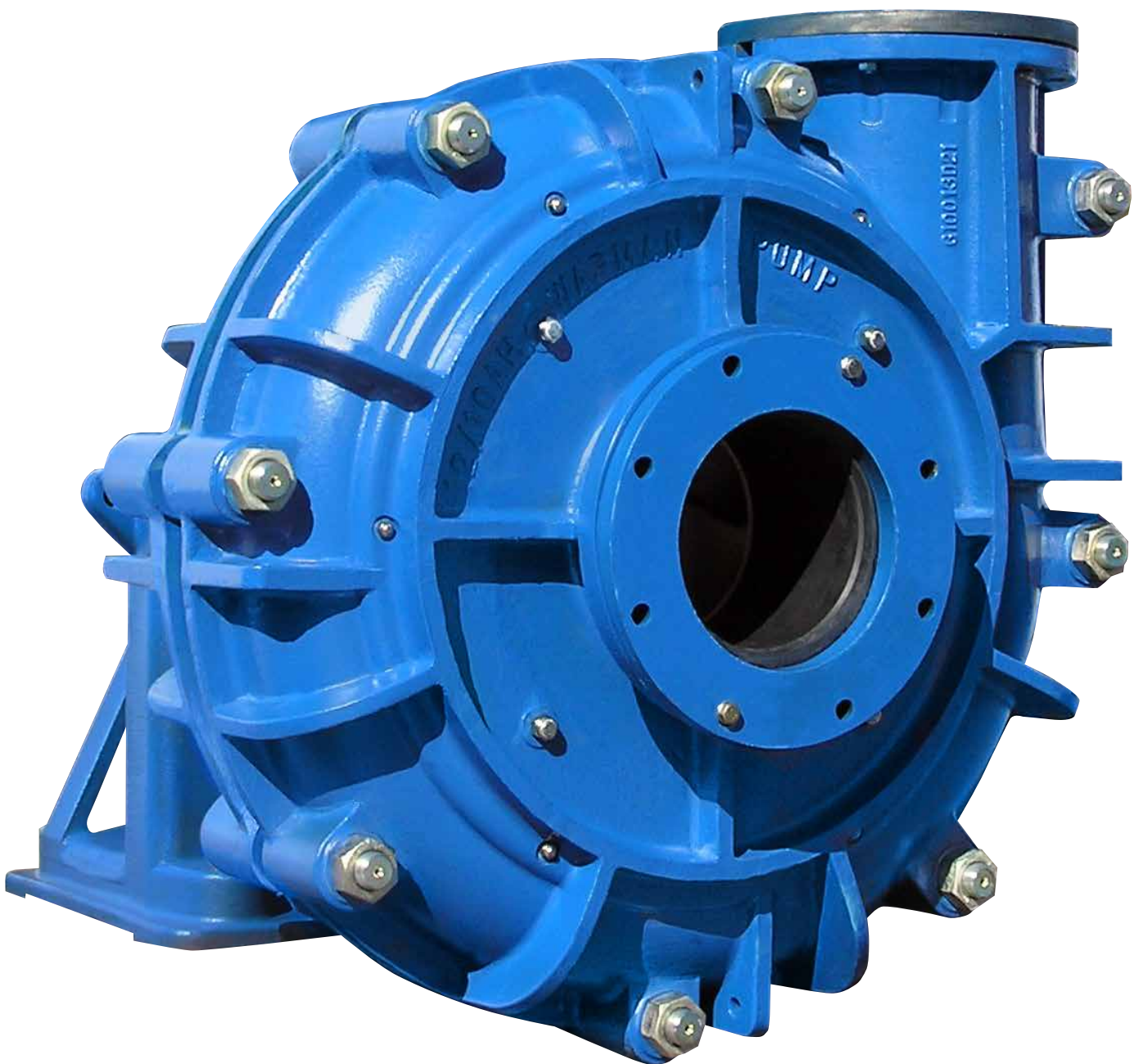

The classic Warman® AH® pump continuously evolves— resulting in improvements in performance and never compromising on the quality that you have come to expect



History

Since the introduction of the first AH® pump model more than half a century ago, feedback from our customers and data from engineers have given us the opportunity to make innovative design upgrades and improvements over the years. Considering important issues, including wear life, component arrangement, material composition and slurry abrasiveness, our slurry pump range continues to increase and our designs continue to evolve.

Today Weir Minerals continues to offer a variety of impellers and shaft seals to ensure a perfect fit for a wide range of customer applications, and a continuing commitment to global retrofitability.

Warman® WRT® impeller and throatbush combination

Our commitment to improvement continues with introduction of the Warman® WRT® impeller and throatbush design. The WRT® impeller and throatbush combination is a superior upgrade for your existing AH® pump, and is designed to enhance efficiency and improve wear performance.

The Warman® WRT® impeller and throatbush combination's new four vane impeller design incorporates a unique vanelet on the back shroud which streamlines the flow through the impeller.



Heavy duty pumping applications

The heavy duty AH® pump range is designed to perform continuous pumping of highly abrasive/dense slurries in processes from hydrocyclone feed to regrind, flotation and tailings in minerals processing plants as well as other industrial applications.

- Ball mill discharge
- Bottom/fly ash, lime grinding
- Coal
- Coarse sand
- Coarse tailings
- Dredging
- FGD
- Fine tailings
- Flotation
- Heavy media
- Minerals concentrate
- Mineral sands
- Ni acid slurry
- Oil sands
- Phosphoric acid
- Phosphate matrix
- Process chemical
- Pulp and paper
- Rod mill discharge
- SAG mill discharge
- Wet crushers



The versatile, fully lined Warman® AH® pump offers a wide range of configurations allowing the pump to be tailored to the customer's specific application

Design features and benefits

- Heavy duty construction with through-bolt design provides ease of maintenance and minimal downtime
- Ductile iron fully lined casing provides durability, strength, safety, and long service life
- Large diameter, slow turning, high efficiency impellers designed to achieve maximum wear life and low operating costs
- Large, open internal passages designed to reduce internal velocities, maximise wear life and lower operating costs
- Thick elastomer or alloy bolt-in liners provide superior corrosion resistance plus offer ease of liner change-out and interchangeability to reduce overall maintenance costs and maximise wear life
- Minimal shaft/impeller overhang reduces shaft deflection and increases packing life
- Cartridge-style bearing assembly allows for maintenance in a clean environment without removal of the pump, resulting in reliable operation and prolonged bearing life
- Grease or oil lubrication bearing assembly options offer ease of maintenance and reduced downtime
- Optional dry running shaft seal reduces or eliminates flush water requirements
- Effective expeller prolongs packing life while reducing or eliminating flush water requirement
- Now featuring Warman® WRT® throatbush and impeller combination designed to enhance efficiency and improve wear performance
- Interchangeability of seal arrangements – full flush, low flow, centrifugal, or mechanical seals may be fitted to any sized pump

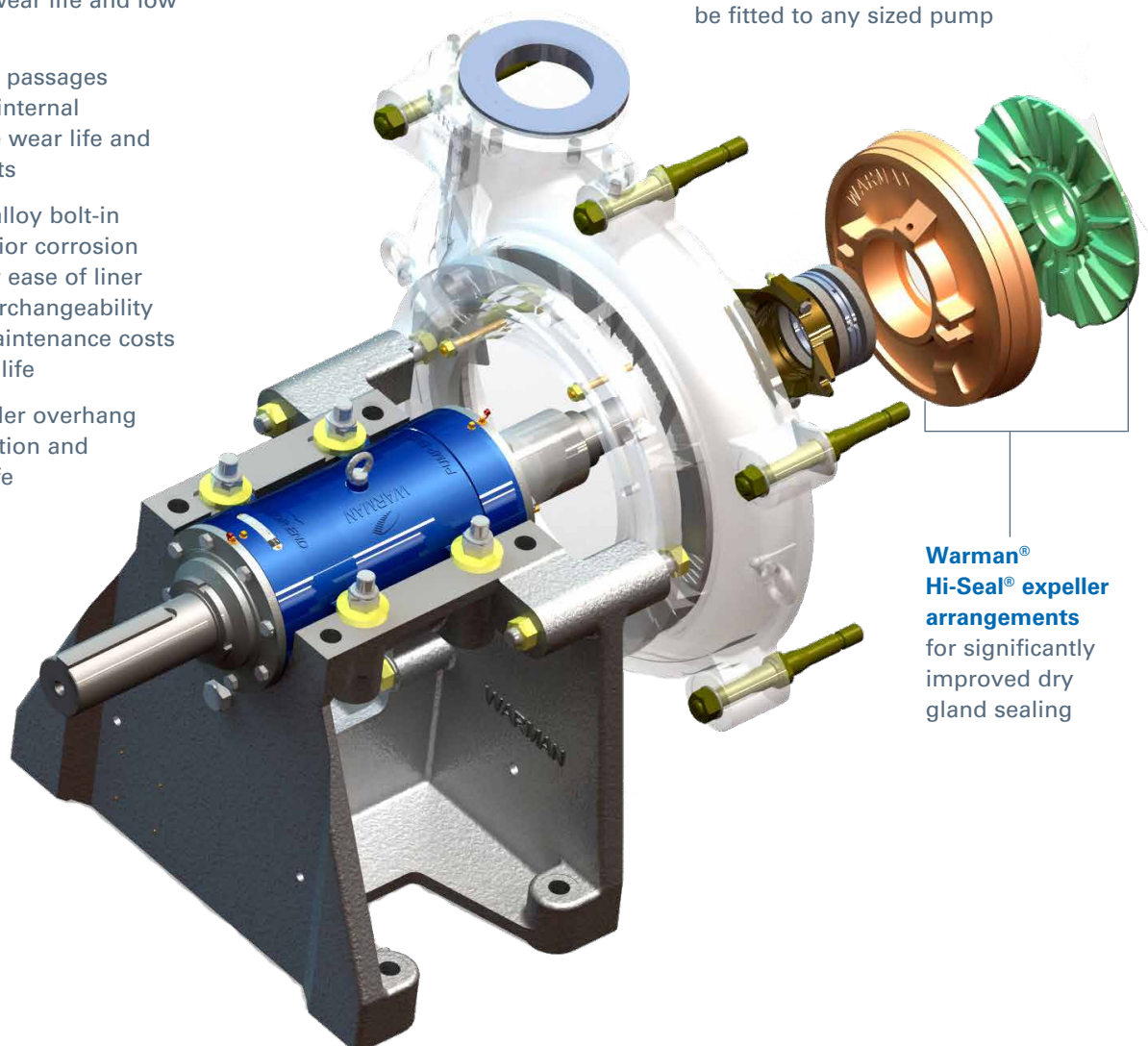

**Warman®
Hi-Seal® expeller
arrangements**
for significantly
improved dry
gland sealing

The WRT® impeller and throatbush combination with improved hydraulic profiles, reduced turbulence, extended wear performance and lower power consumption.

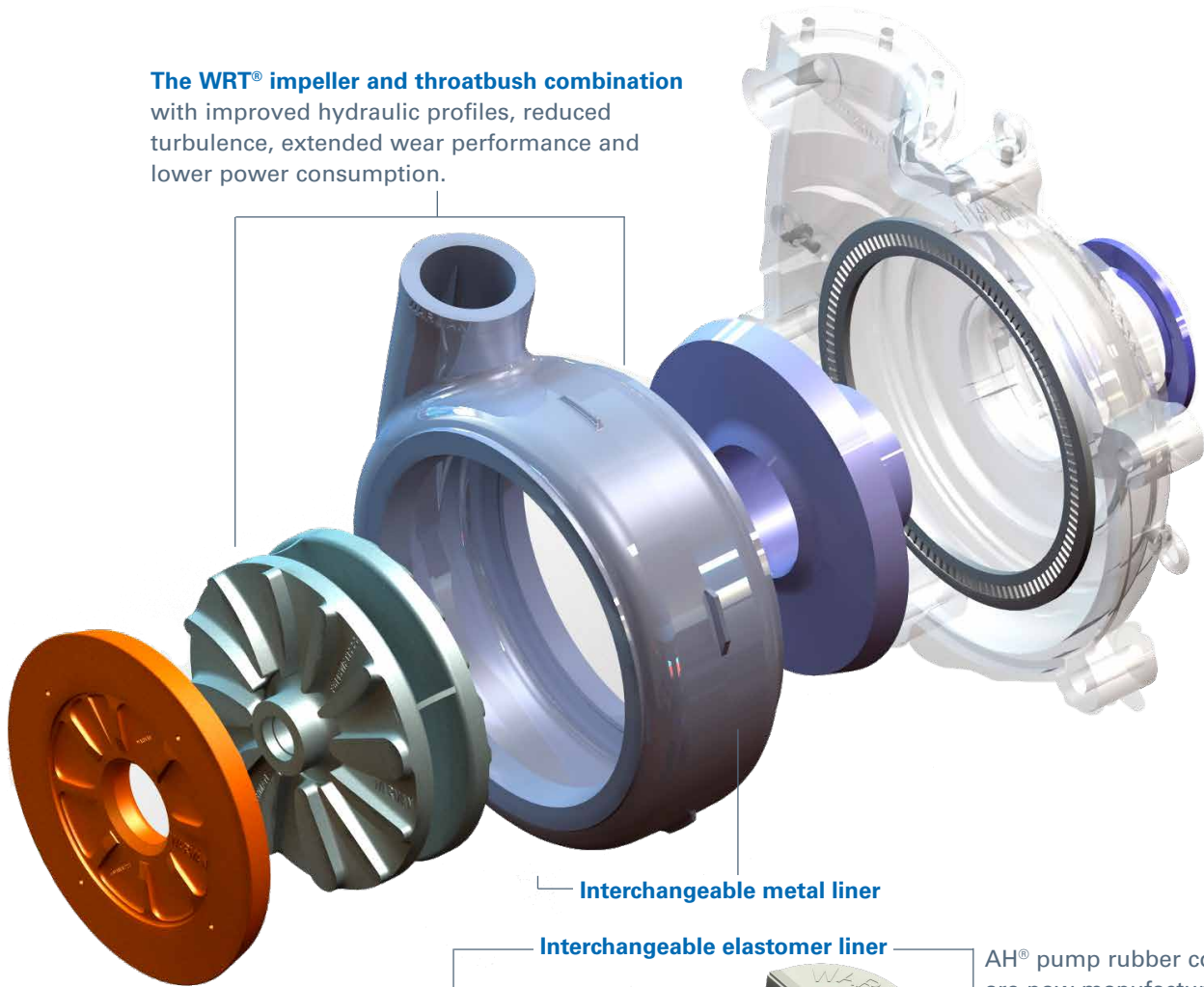

Interchangeable metal liner

Interchangeable elastomer liner

AH® pump rubber components are now manufactured in the Warman® R55® compound

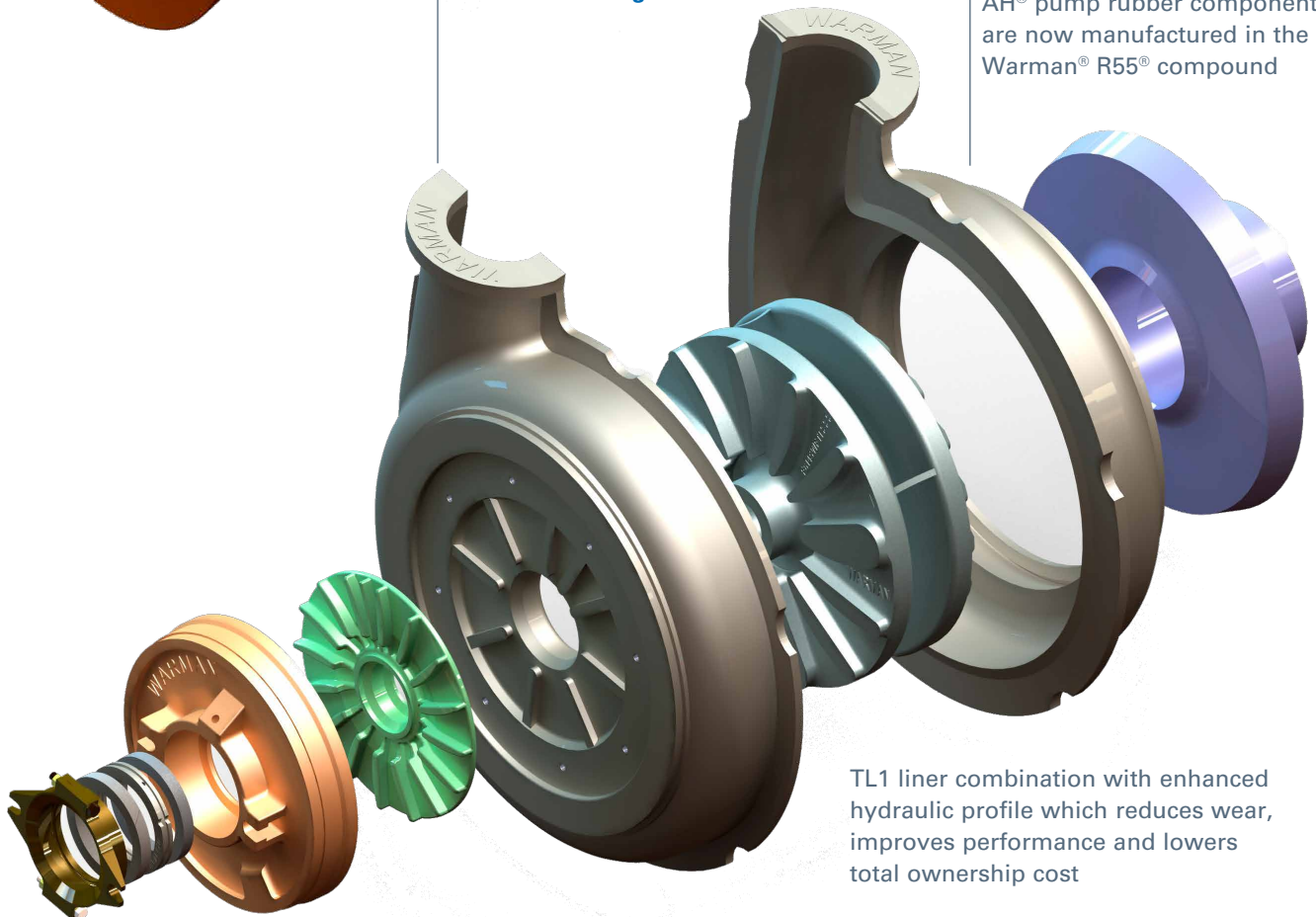

TL1 liner combination with enhanced hydraulic profile which reduces wear, improves performance and lowers total ownership cost

Warman® AH®, AHP and AHPP slurry pump - outline dimensions

To be used for preliminary selection only. All measurements in mm.

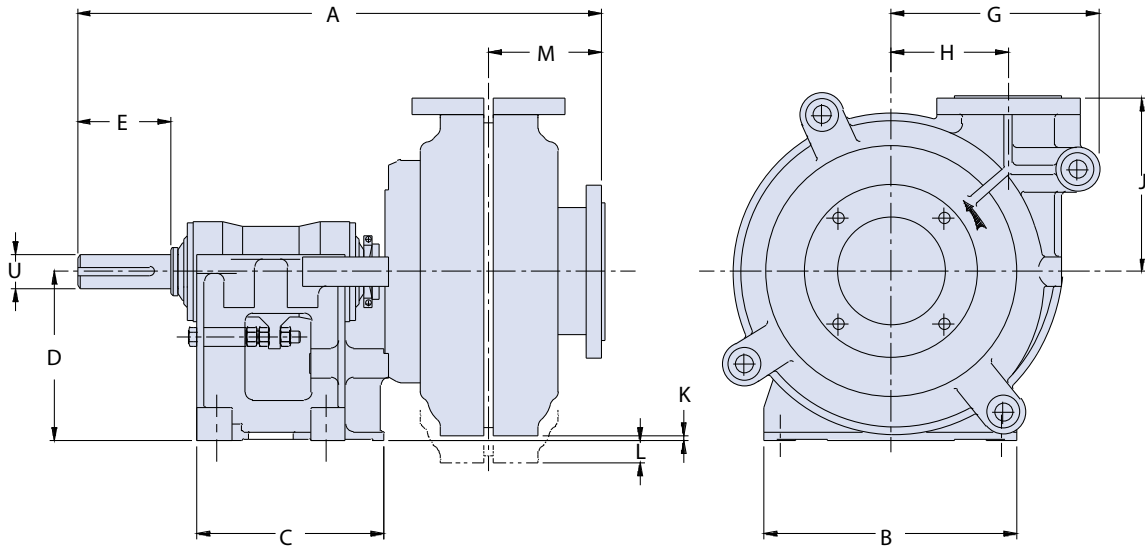

Pump Size	A	B	C	D	U	Key Size	E	G	H	J	K	L	M	Approximate mass (kg)	
	mm	mm	mm	mm	mm	mm	mm	mm	mm	mm	mm	mm	mm	metal	rubber
1.5/1 BAH	583	295	248	197	28	8X7	79	181	98	171	46	-	106	90	75
2/1.5 BAH	596	295	248	197	28	8X7	79	203	114	184	33	-	115	100	85
3/2 CAH	777	406	311	254	42	12X8	122	238	138	210	67	-	156	200	160
4/3 CAH	848	406	311	254	42	12X8	121	292	149	262	20	-	192	300	230
4/3 DAH	948	492	364	330	65	18X11	152	292	149	262	100	-	192	380	280
6/4 DAH	1028	492	364	330	65	18X11	150	406	229	338	12	-	228	660	420
6/4 EAH	1188	622	448	457	80	22X14	220	406	229	338	139	-	228	810	620
6/4 EEAHP	1240	622	448	457	85	22X14	222	435	229	460	49	-	230	1110	980
8/6 EAH	1318	622	448	457	80	22X14	222	551	318	460	-	62	292	1510	980
8/6 FAH	1518	857	635	610	100	28X16	279	551	318	460	91	-	304	1650	1160
8/6 FFAHPP	1569	857	635	610	120	32X18	290	615	318	615	16	-	304	2920	2480
10/8 FAH	1650	990	705	610	100	28X16	279	667	419	635	-	12	334	2650	1970
10/8 STAH	1753	1150	780	650	120	32X18	280	667	419	635	28	-	334	3450	3210
10/8 STAHP	1755	1150	780	650	120	32X18	280	760	419	735	-	69	334	5020	4530
10/8TAHPP	2136	1150	1040	650	150	36X20	350	760	419	735	-	70	334	5850	5150
12/10 FAH	1721	990	705	610	100	28X16	279	749	464	673	-	104	381	4080	3040
12/10 STAH	1827	1150	780	650	120	32X18	280	749	464	673	-	64	381	4470	3730
12/10 TAH	2204	1150	1040	650	150	36X20	350	749	464	673	-	64	381	5200	4570
*12/10 TAHPP	2190	1150	1040	650	150	36X20	350	950	464	800	-	130	382	7520	6800
*12/10 TAHPP	2242	1150	1040	650	150	36X20	350	950	464	800	-	119	420	8280	7050
14/12 FAH	1777	990	705	610	100	28X16	279	944	629	832	-	264	406	5900	4180
14/12 STAH	1879	1150	780	650	120	32X18	280	944	629	832	-	224	406	5490	4870
*14/12TAHPP	2336	1150	1040	650	150	36X20	350	1100	629	930	-	248	485	12020	10500
16/14 TUAH	2320	1460	1050	900	150	36X20	350	1048	660	889	-	84	451	10560	7860
*16/14TUAHPP	2424	1460	1050	900	150	36X20	350	1300	660	1035	-	140	540	16280	14470
20/18 TUAH	2475	1460	1050	900	150	36X20	350	1414	940	1230	-	417	580	17760	12890
*20/18TUAHP	2475	1460	1050	900	150	36X20	350	1600	940	1230	-	305	580	20450	14150
*20/18TUAHPP	2475	1460	1050	900	150	36X20	350	1600	940	1230	-	305	580	23140	17230

Note: U dimensions and key sizes are in millimeters. All others are in inches.

*These pump sizes have additional mounting feet on the casing.

Warman® AH® slurry pump - quick selection guide

Approximate clear water performance - to be used for preliminary selection only.

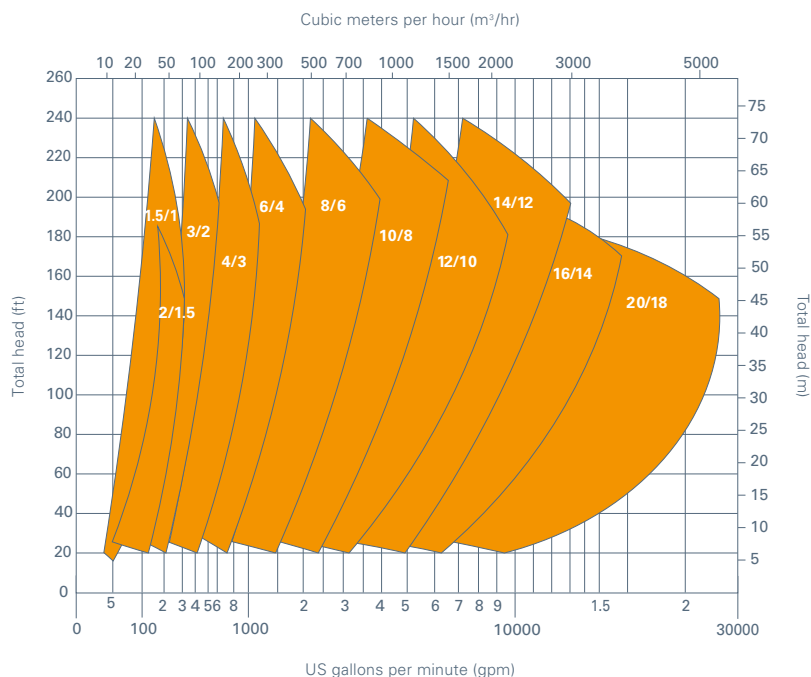

Warman® AH® pumps upgraded with WRT® impeller and throatbush combination improve wear life and lower power consumption

Background

The operational wear life of the Warman® AH® pumps installed in DMS ferrosilicon feed service for a customer located in the Pilanesburg Mountain region in South Africa was falling short and they were looking for improvement.

In order to meet the customer's needs the existing AH® pumps were upgraded with the Warman® WRT® impeller and throatbush combination to improve wear life and lower power consumption

Results

The Warman® AH® pumps fitted with the WRT® impeller and throatbush combination demonstrated improved wear life in this trial compared to a pump fitted with standard AH® impeller and throatbush components.

- Wear life extended by 1,944 hours using the WRT® impeller and throatbush combination
- Increase in power cost savings
- Decrease in maintenance downtime
- Stopped the pump cavitating

Duty information

Flow (m³/h)	1062
TH (m)	42
Slurry (SG)	3.2
Solid (SG)	6.8
Percent solids (Cw)	19.5
Solids d50 (mm)	20

Wear life comparison

AH® 10/8 FF	
impeller	1296 hours
throatbush	1296 hours
WRT® 10/8 FF	
impeller	3240 hours
throatbush	3240 hours

Performance per pump	WRT® 10/8 FF	AH® 10/8 FF
kW absorbed	296	313
Pump RPM	692	704
Pump efficiency %	65.51	62.00
NPSH available	3.16	3.16
NPSH required by pump	2.11	3.30
Is pump cavitating?	No	Yes



Minerals

Weir Minerals Australia Ltd

1 Marden Street
Artarmon NSW 2064
Australia

Tel: +61 (0)2 9934 5100
Fax: +61 (0)2 9934 5201
info@weirminerals.com

www.weirminerals.com

