



GEA Hilge durietta 0

Compact, Single- and Multi-Stage Centrifugal Pumps

Reliable and Compact Performance

The GEA Hilge durietta 0 is a close-coupled end-suction single- or multi-stage centrifugal pump created for all kinds of applications that call for sanitary pump equipment.

A Solid Pump for Superior Hygiene

The GEA Hilge durietta 0 is designed in compliance with food technology requirements, making it ideal for jobs where hygiene is a key concern. For example, it is CIP- and SIP-capable with the performance characteristics outlined for pumps in DIN 12462.

Applications

The unique hygienic design and the deep-drawn, rolled stainless steel AISI 316L makes the GEA Hilge durietta 0 pump range suitable for:

Food & Beverage

- Microbreweries and dairies
- Bottling systems
- Food processing plants
- Drinking water systems
- CIP systems

Pharmaceutical and Related Industry

- Purification systems
- Personal care industries
- CIP systems

Other Industrial Applications

- Semi-conductor manufacturing
- CIP systems
- Heat exchangers

Mechanical Shaft Seal

GEA Hilge offers various seal arrangements:

- Single mechanical seal
- Double mechanical seal, tandem

The standard mechanical shaft seal has an optimum position in the pump housing. This ensures lubrication and cooling of the mechanical seal in accordance with the criteria of hygienic design.

Features and Benefits

- 1 Connections**
Flexible connections
- 2 Shaft seal**
Optimal position in the pump housing
- 3 Surface**
Electro-polished for easy cleaning

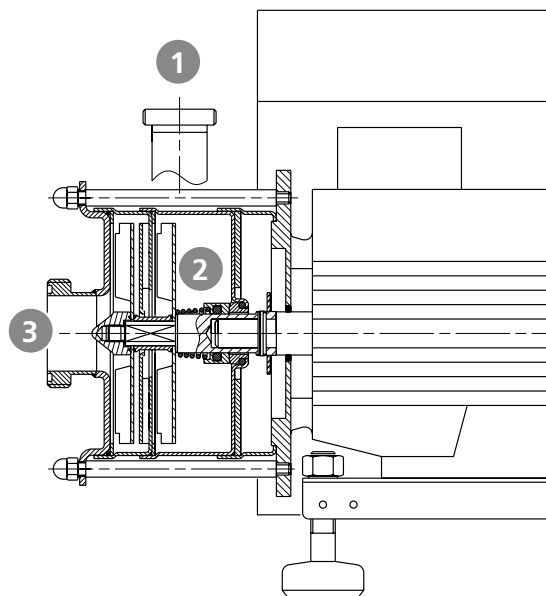



Connections

GEA Hilge offers threads to DIN 11851 as standard for GEA Hilge durietta 0 pumps.

Connections on Request

Threads:

- Threads, SMS
- Threads DIN 11864-1

Flanges:

- Flanges EN 1092-1 (DIN 2642)
- Flanges DIN 11864-2

Clamps:

- Clamps, TRI-CLAMP

Other connections are available on request.

Impeller

The durietta 0 has semi-open impellers which allows easy and sufficient cleaning.

Customized Solutions

Customization is one of the highlights of the GEA Hilge durietta 0 pump range. The range of these single- and multi-stage sanitary pumps allows you to choose between several variants to suit your task.

Design variants – durietta 0

Standard variants	Description
GEA Hilge durietta 0 K	Horizontal installation, closed-coupled pump with plug-in shaft
GEA Hilge durietta 0 K SUPER	Horizontal installation, motor with stainless steel shroud on stainless steel foot, closed-coupled pump with plug-in shaft



GEA Hilge durietta 0

Technical data		
GEA Hilge durietta 0	50 Hz	60 Hz
Flow	8 m ³ /h	8 m ³ /h
Head	75 m	42 m
Operating temperature	95 °C	
Operating pressure	max. 8 bar	

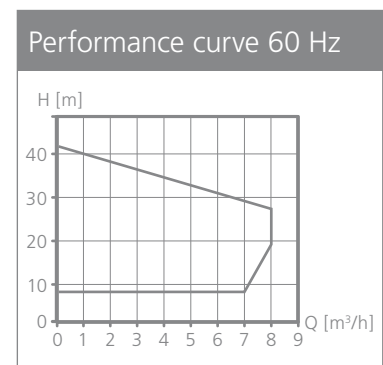
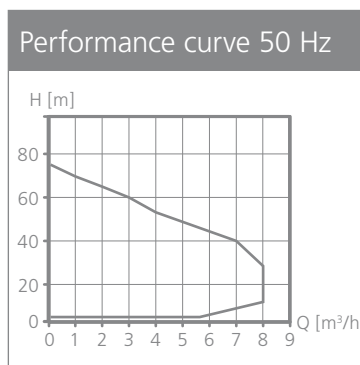



We live our values.

Excellence • Passion • Integrity • Responsibility • GEA-versity

GEA Group is a global engineering company with multi-billion euro sales and operations in more than 50 countries. Founded in 1881, the company is one of the largest providers of innovative equipment and process technology. GEA Group is listed in the STOXX® Europe 600 Index.

Hilge GmbH & Co. KG

Hilgestraße, 55294 Bodenheim, Germany
Phone 06135-75 0, Fax 06135-75 4955
info@gea.com, www.gea.com