



GEA Hilge Euro-HYGIA®
Single-Stage Centrifugal Pumps

More Flexibility for your Process Applications

The premium pump series GEA Hilge Euro-HYGIA® consists of single-stage end-suction centrifugal pumps, constructed for use in industries with high demands to hygiene and flexibility.

Corresponds to the Highest Global Hygiene Requirements

Produced of high-quality materials that meet the highest global hygiene standards, GEA Hilge Euro-HYGIA also offers a high level of flexibility. Apart from DIN, ASME and ISO connections, a flexible range of custom connections is available upon request. The pumps are equipped with operating-point-optimized impellers. Different impeller geometries are available for this.

The GEA Hilge Euro-HYGIA® pump can be flexibly employed in all application ranges in which reliable hygienic pump function is required. This includes the following areas:

Life Science/Pharmaceutics Industry

- Pumping of sterile and pure water (WFI)
- Biotechnology
- Infusions (nutrient solutions, alcohol)
- Filling stations

Personal Care

- Purified water, WFI
- Lotions
- Perfumes

Food & Beverage Industry

- Beer/breweries
- Dairies
- Soft drinks
- Yeast processing

Additional Industrial Applications

- Cleaning processes (CIP systems)
- Water technology processes
- Semiconductor production
- Metal surface treatment

Suitable for the Highest Standards

The materials used for GEA Hilge Euro-HYGIA® pumps have been selected for the use in hygienic processes. The housings are made of CrNiMo rolled steel (1.4404/1.4435) and have a smooth surface without pores and blowholes.

Features and Benefits

- 1 Optimized impeller**
Open and closed impellers available as well as free-flow impellers
- 2 Hygienic construction**
The constructional design allows optimal cleaning (CIP) and sterilisation (SIP)
- 3 Inboard mechanical seal**
For effective cleaning, cooling and lubrication
- 4 Dead end free design**
The pumps meet the highest hygienic demands to avoid contamination

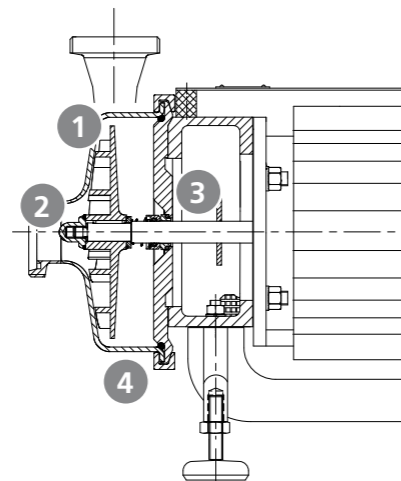

Certification-Compliant

GEA Hilge Euro-HYGIA® pumps are CIP/SIP-able according to the performance criteria for pumps according to DIN EN 12462. The media-contacting parts meet the requirements of the QHD-standards and the EHEDG with test certificate as proof of CIP cleaning capacity.

Mechanical Seals – choose the one to suit you

A wide range of mechanical seal options is available to suit different media and applications. The mechanical seals used in the GEA Hilge Contra range are single inboard seals that maintain the optimum position in the liquid.

Choices include:

- Single mechanical seals in sterile execution
- Double mechanical seals (tandem or back-to-back)
- Standard seal face material: carbon/stainless steel and SiC/SiC
- Standard O-ring material: EPDM (FDA-compliant)
- Additional designs and materials available upon request.

Design variations – Euro-HYGIA®	
Standard variants	Description
GEA Hilge Euro-HYGIA® Adapta®	Close-coupled pump with bearing bracket and coupling, horizontal installation
GEA Hilge Euro-HYGIA® Adapta® SUPER	Close-coupled pump with bearing bracket and coupling, horizontal installation, motor with stainless steel shroud
GEA Hilge Euro-HYGIA® Bloc	Close-coupled pump on a cast base or calotte stand, horizontal installation
GEA Hilge Euro-HYGIA® Bloc-SUPER	Close-coupled pump, motor with stainless steel shroud, horizontal installation
Variants upon request	Description
GEA Hilge Euro-HYGIA® tronic	Motor with built-in frequency converter



GEA Hilge Euro-HYGIA® Adapta® with built-in frequency converter

Technical data		
GEA Hilge Euro-HYGIA®	50 Hz	60 Hz
Flow	110 m³/h	110 m³/h
Head	70 m	90 m
Operating temperature	up to 95 °C, (150 °C upon request)	
Sterilization temperature	up to 140 °C (SIP)	
Operating pressure	PN 16 (PN 25 upon request)	

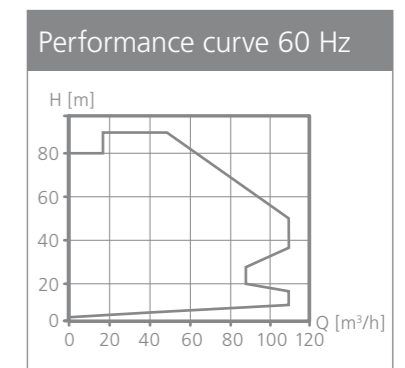
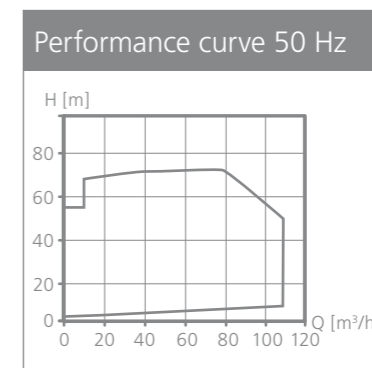



We live our values.

Excellence • Passion • Integrity • Responsibility • GEA-versity

GEA Group is a global engineering company with multi-billion euro sales and operations in more than 50 countries. Founded in 1881, the company is one of the largest providers of innovative equipment and process technology. GEA Group is listed in the STOXX® Europe 600 Index.

Hilge GmbH & Co. KG

Hilgestraße, 55294 Bodenheim, Germany
Phone 06135-75 0, Fax 06135-75 4955
info@gea.com, www.gea.com